

## Memorandum

DATE: September 17, 2021  
FROM: Christine Schwake  
RE: Rationale for Section 401 Water Quality Certification for 2021-1376 Anthony Nielsen

---

**Project Proponent:** Anthony Nielsen

**Corps #:** 2021-1376

**DNR #:** 21-W-059-09-05-S

**Project Description:** Place 2 short boulder walls and native field stone along 60' of West Okoboji Lake. (See Attachment 1, for further detail.)

**Project Location:** 2920 Manhattan Boulevard, Wahpeton, S13, T99N, R37W, in Dickinson County.  
Latitude: 43.3948, Longitude: -95.1683.

### Receiving Streams

West Okoboji Lake is an A1, B(LW) HH, Class C designated use waterbody. The designations have been adopted in Iowa's state rule described in the rule-referenced document of Surface Water Classification effective on July 24, 2019.

West Okoboji Lake is also an Outstanding Iowa Water (OIW). Activities on OIWs, listed at the [DNR Antidegradation webpage](#), must obtain individual 401 certification. In accordance with the Iowa Antidegradation Implementation Procedure (2010 and 2016), "[t]emporary and limited degradation of OIWs or degradation caused by the expansion of existing sources may be allowed by the department on a case-by-case basis as explained in Subsections 1.2 & 2.4 of this document."

### Antidegradation

#### Pollutants of Concern

This project proposes to place field stone boulders along West Okoboji Lake. Chemicals will not be used. Thus, the pollutants present in the discharge from such construction are substances present in runoff, or are the result of a spill. The DNR has identified the following pollutant of concern in discharges from this project and the potential impacts on water quality:

#### *Increased Turbidity/Total Suspended Solids*

The turbidity of water is related to the amount of suspended solids contained in the water. Suspended solids decrease the clarity of water, reduce light penetration, and can impair the photosynthetic activity of aquatic plants. Suspended solids can be aesthetically displeasing and can reduce the recreational value of a water body. If suspended solids screen out light and impair growth of aquatic plants, dissolved oxygen levels can decrease. Suspended solids can be harmful to fish and other aquatic life by causing abrasive injuries and clogging gills and respiratory passages.

Increases in turbidity/total suspended solids from projects authorized by NWP 13 will generally be temporary and limited. To address turbidity/total suspended solids, projects authorized under NWP 13 will control runoff to water bodies using a variety of best management practices (BMPs).

#### Best Management Practices in Permit and Certification Conditions

##### *Permit-Based BMPs*

The Corps has BMP-based conditions for NWP 13. See Attachment 2 for the Iowa Fact Sheet No. 8 which contains information regarding NWP 13 as well as the BMP-based conditions. Pre-construction notification is required for activities authorized by this nationwide permit. This allows the Corps to review every project to ensure that adverse impacts to the aquatic environment are no more than minimal.

### Certification-Based BMPs

The DNR has added BMP-based conditions to this NWP via certification. See Attachment 3 for the draft certification.

The combined listed BMPs, when adhered to by the permittee, protect Iowa's water quality by controlling erosion and sediment runoff to prevent pollution from reaching the nearby water bodies. Antidegradation requirements will be considered to be met if all appropriate and reasonable BMPs required by permit and certification are applied and maintained. See, 567 IAC 61.2(2); Iowa Antidegradation Implementation Procedure § 6.3.

### Temporary and Limited Degradation

The State adopted Iowa Antidegradation Implementation Procedure (2010 and 2016) states that "A regulated activity shall not be considered to result in degradation, if the activity will result in only temporary and limited degradation of water quality as defined in the glossary and as further described in Sections 1.2 and 2.4." The effects can be regarded as temporary and limited following a review of all of the following factors, if applicable:

#### *a) Length of time during which water quality will be lowered*

The length of time where there might be a lowering of water quality is relatively short for construction authorized under NWP 13 (it is anticipated that it will take approximately 3 months to complete the project).

#### *b) Percent change in ambient conditions*

The only significant change that is reasonably expected to occur would be for the presence of sediment in the lake if there is a heavy rainstorm or if the BMPs fail.

#### *c) Pollutants affected*

Turbidity, total suspended solids

#### *d) Likelihood for long term water quality benefits to the water body*

The bank stabilization helps with controlling erosion of the shoreline.

#### *e) Degree to which achieving the applicable Water Quality Standards during the proposed activity will be at risk*

The use of BMPs installed prior to construction, maintained during construction, and until the site has returned to pre-construction conditions should greatly increase the degree to which a project achieves the applicable water quality standards.

#### *f) Potential for any residual long term effects on existing uses*

The BMP-based conditions included in the NWP 13 and draft certification include activities such as appropriate riprap, reseeding disturbed areas, and properly disposing of construction debris. This project should not contribute to any ongoing impacts to water quality.

### For the above discussed reasons, the DNR makes the following finding:

This review concludes that water quality degradation due to this bank stabilization activity authorized under NWP 13 is temporary and limited.

### Social and Economic Importance

Bank stabilization protects the shoreline from erosion and increase the property value.

### For the above discussed reasons, the DNR makes the following finding:

This review concludes that water quality degradation due to this activity authorized using NWP 13 is necessary to accommodate important economic and social development.



17. DIRECTIONS TO THE SITE

Residential property, starting at Highway 86, continue west on 175th Street to Manhattan Boulevard, continue north to 2920 Manhattan Boulevard on the east side of the street.

18. Nature of Activity (Description of project, include all features)

Streambank/Shoreline Protective Devices: The lakeshore has been protected with riprap and vegetation. The lakeshore has experienced surface erosion over the years. The plan is to place two short boulder walls to make it easier to maintain the bank. The bank will have 12"-18" clean native riprap placed with engineering fabric (60' wide) and new vegetation. These measures will reduce the erosion that has been occurring at this site. New walls will be approximately 60' wide and 3.5-4' in height.

19. Project Purpose (Describe the reason or purpose of the project, see instructions)

Moderate erosion has occurred along the bank on the West Okoboji lakeshore causing the bank to erode. The new boulder walls and riprap will help reduce erosion.

**USE BLOCKS 20-23 IF DREDGED AND/OR FILL MATERIAL IS TO BE DISCHARGED**

20. Reason(s) for Discharge

Not Applicable

21. Type(s) of Material Being Discharged and the Amount of Each Type in Cubic Yards:

Types: Not Applicable

Amounts: Not Applicable

22. Surface Area in Acres of Wetlands or Other Waters Filled (see instructions)

Not Applicable

23. Description of Avoidance, Minimization, and Compensation (see instructions)

Not Applicable

24. Is Any Portion of the Work Already Complete?  Yes  No IF YES, DESCRIBE THE COMPLETED WORK

25. Addresses of Adjoining Property Owners, Lessees, Etc., Whose Property Adjoins the Waterbody (if more than can be entered here, please attach a supplemental list).

26. List of Other Certificates or Approvals/Denials received from other Federal, State, or Local Agencies for Work Described in This Application.

\* Would include but is not restricted to zoning, building, and flood plain permits

27. Application is hereby made for permit or permits to authorize the work described in this application. I certify that this information in this application is complete and accurate. I further certify that I possess the authority to undertake the work described herein or am acting as the duly authorized agent of the applicant.

Jeffrey Rose

09/16/2021

\_\_\_\_\_  
SIGNATURE OF APPLICANT

\_\_\_\_\_  
DATE

\_\_\_\_\_  
SIGNATURE OF AGENT

\_\_\_\_\_  
DATE

The Application must be signed by the person who desires to undertake the proposed activity (applicant) or it may be signed by a duly authorized agent if the statement in block 11 has been filled out and signed.

18 U.S.C. Section 1001 provides that: Whoever, in any manner within the jurisdiction of any department or agency of the United States knowingly and willfully falsifies, conceals, or covers up any trick, scheme, or disguises a material fact or makes any false, fictitious or fraudulent statements or representations or makes or uses any false writing or document knowing same to contain any false, fictitious or fraudulent statements or entry, shall be fined not more than \$10,000 or imprisoned not more than five years or both.



## Additional Information

Anticipated Activity Start Date: 10/11/2021

Anticipated Activity Completion Date: 12/31/2021

1. Is any portion of the work already complete?  Yes  No

If yes, describe the completed work:

2. Do you have any funding deadlines that pertain to the completion of your project?  Yes  No

If yes, explain:

3. Is the need for a permit the result of an unforeseen emergency or catastrophic event? Yes No

If yes, explain:

4. Is permit needed to complete a project that will abate or prevent an imminent threat to the public health and welfare?  Yes  No

If yes, explain:

5. Will any federal funding be used on this project?  Yes  No

If yes, explain:

6. If dredging will occur with this project, please specify the date of the last dredge event that took place, if applicable, and how much material was removed?  Yes  No

If yes, explain:

7. For projects located on Sovereign Land, are you requesting a permanent easement from the State of Iowa acting through the Iowa DNR?  Yes  No

### Consent to Enter Property

Agency personnel may make one or more field inspections of the project site when necessary to obtain information about the project. Submission of the application is deemed to constitute consent by the applicant for the agency staff and its agents to enter.

Consent to Enter Property?  Yes  No

If no, explain:

### Additional Information

Do you have any additional information that we should know about regarding your application?

86

14

Property Location

13

( WAHPETON CORP. (SLIM) )

( WAHPETON CORPORATE LIMITS )

WAHPETON

MANHATTEN BLVD  
( WAHPETON CORPORATE LIMITS )

West Okoboji Lake

23

24

( WAHPETON CORPORATE LIMITS )

( WAHPETON CORPORATE LIMITS )

A22





GROUP 1  
SECTION 1

DATUM ELEV  
73

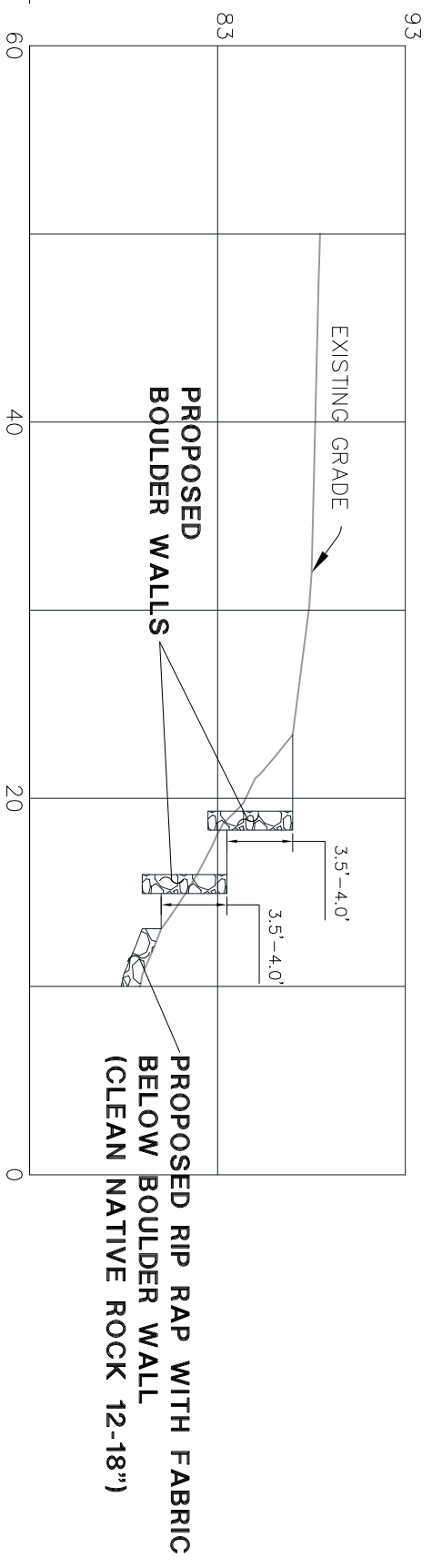

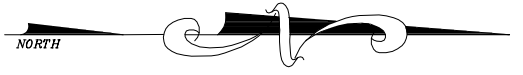

LOT 10

MANHATTAN BEACH  
BLOCK "A"

OWNER OF RECORD:  
ANTHONY & JULIE NIELSEN  
2920 MANHATTAN BOULEVARD

LOT 11

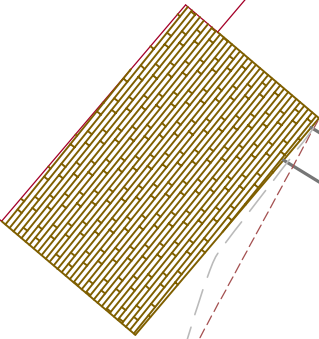

LOT 12

LAKE SIDE DRIVE

WEST OKOBOJI LAKE

PROPOSED  
BOULDER WALLS  
REMOVE &  
REPLACE STEPS

PROPOSED  
BOULDER WALLS

PROPOSED RIP RAP WITH FABRIC  
BELOW BOULDER WALL  
(CLEAN NATIVE ROCK 12-18")

PROPOSED SILT FENCE  
OR FLOATING SILT FENCE

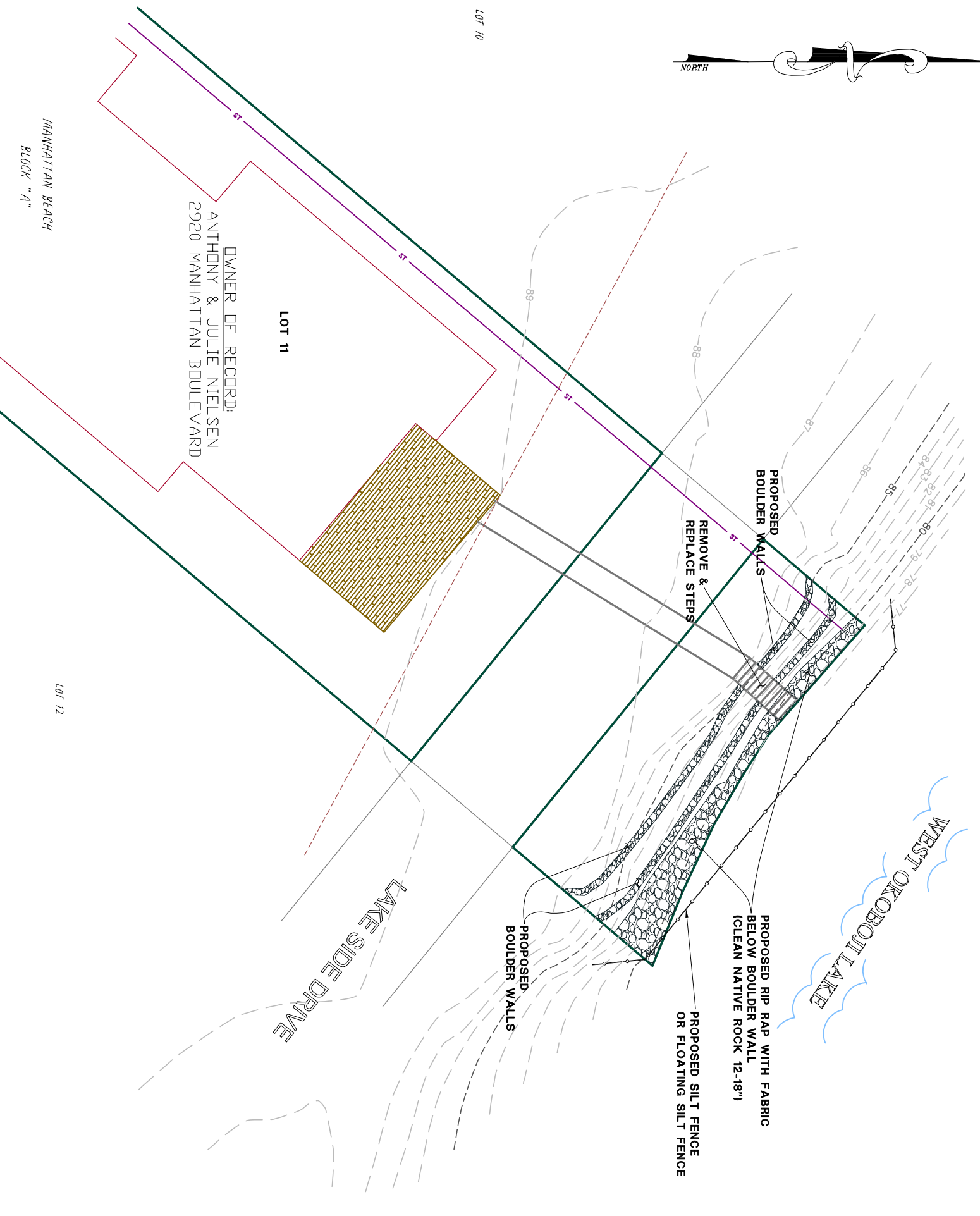



US Army Corps  
of Engineers  
Rock Island District

## FACT SHEET NO. 8(IA)

NATIONWIDE PERMITS IN IOWA

EFFECTIVE DATE: MARCH 19, 2017

On January 6, 2017, the Corps of Engineers published in the Federal Register (82 FR 1860), the Final Rule for the Nationwide Permits Program under the Rivers and Harbors Act of 1899; the Clean Water Act; and the Marine Protection, Research and Sanctuaries Act. These Nationwide Permits became effective on March 19, 2017.

The Nationwide Permit Program is an integral part of the Corps' Regulatory Program. The Nationwide Permits are a form of general permits issued by the Chief of Engineers and are intended to apply throughout the entire United States and its territories. A listing of the nationwide permits and general conditions is included herein. We encourage prospective permit applicants to consider the advantages of nationwide permit authorization during the preliminary design of their projects. Assistance and further information regarding all aspects of the Corps of Engineers Regulatory Program may be obtained by contacting the appropriate Corps of Engineers District at the address and/or telephone number listed on the last page of this Fact Sheet.

**Regional Conditions:** To ensure projects authorized by a Nationwide Permit will result in minimal adverse effects to the aquatic environment, the following **Regional Conditions** were developed for projects proposed within the state of Iowa:

1. Side slopes of a newly constructed channel will be no steeper than 2:1 and planted to permanent, perennial, native vegetation if not armored.
2. Nationwide permits with mitigation may require recording of the nationwide permit and pertinent drawings with the Registrar of Deeds or other appropriate official charged with the responsibility for maintaining records of title to, or interest in, real property and require the permittee to provide proof of that recording to the Corps.
3. Mitigation shall be scheduled prior to, or concurrent with, the discharge of dredged or fill material into waters of the United States, unless an alternate timeline is specifically approved in the authorization.
4. For newly constructed channels through areas that are unvegetated, native grass filter strips, or a riparian buffer with native trees or shrubs a minimum of 35 feet wide from the top of the bank must be planted along both sides of the new channel. A survival rate of 80 percent of native species shall be achieved within three years of establishment of the buffer strip.
5. For single-family residences authorized under nationwide permit 29, the permanent loss of waters of the United States (including jurisdictional wetlands) must not exceed 1/4 acre.
6. For nationwide permit 46, the discharge of dredged or fill material into ditches that would sever the jurisdiction of an upstream water of the United States from a downstream water of the United States is not allowed.
7. For projects that impact an Outstanding National Resource Water, Outstanding Iowa Water, fens, bogs, seeps, or sedge meadows, a Pre-Construction Notice in accordance with General Condition No. 32 and an Individual Section 401 Water Quality Certification will be required.
8. For nationwide permits when the Corps' District Engineer has issued a waiver to allow the permittee to exceed the limits of the nationwide permit, an Individual Section 401 Water Quality Certification will be required.
9. Operation of heavy equipment within the stream channel should be avoided. If in-stream work is unavoidable, it shall be performed in such a manner as to minimize the duration of the disturbance, turbidity increases, substrate disturbance, bank disturbance, and disturbance to riparian vegetation. This condition does not further restrict otherwise authorized drainage ditch maintenance activities.
10. Any bank stabilization activity involving a method that protrudes from the bank contour, such as jetties, stream bars and/or weirs, will require a Pre-Construction Notice in accordance with General Condition No. 32.
11. Beyond what is described in General Condition # 6, suitable fill material shall consist of clean materials, free from debris, trash, and other deleterious materials. If broken concrete is used as riprap, all reinforcing rods must be cut flush with the surface of the concrete, and individual pieces of concrete shall be appropriately graded and not exceed 3 feet in any dimension. Asphalt, car bodies, and broken concrete containing asphalt, and liquid concrete are specifically excluded.

12. No non-native, invasive or other plant species included on the Corps "Excluded Plant List" shall be planted for re-vegetation or stabilization purposes. The plant list can be found on the Corps website at: <http://www.mvr.usace.army.mil/Missions/Regulatory.aspx>. To prevent the spread of non-native and/or invasive plant species, the permittee shall ensure that equipment to be utilized in Waters of the United States is cleaned before arriving on site. Wash water shall not be discharged into any wetland, waterway, or any other surface water conveyances.

13. All authorizations requested by applicants other than the Tribal Authority for use within lands under the jurisdiction of the Sac and Fox Tribe of the Mississippi in Iowa require preconstruction notification to the District Engineer and coordination with the Tribal Authority.

**State Water Quality Certification:** Permits, issued by the Corps of Engineers, under the authority of Section 404 of the Clean Water Act may not be issued until the state (where the discharge will occur) certifies, under Section 401 of the Act, that the discharge will comply with the water quality standards of the State. On March 03, 2017, the Iowa Department of Natural Resources issued their final Section 401 Water Quality Certification decision.

For projects within the Sac and Fox Tribe of the Mississippi of Iowa, the U.S. Environmental Protection Agency (USEPA) has denied Section 401 Water Quality Certification (WQC) for certain activities. For all other projects authorized by a Nationwide Permit, the USEPA has issued Section 401 WQC with conditions.

The full text of both of the Water Quality Certifications is available on our website under the Nationwide Permit section at: <http://www.mvr.usace.army.mil/Missions/Regulatory/Permits>, they can also be located as attachments at the end of this document.

Under certain circumstances, Nationwide Permits 3, 7, 8, 12, 13, 14, 17, 18, 21, 22, 23, 27, 29, 31, 33, 34, 36, 37, 38, 39, 40, 42, 43, 44, 45, 46, 48, 49, 50, 51, 52, 53 and 54 require that the permittee notify the District Engineer at least 45 days prior to performing the discharge. Specific instructions for these notifications are contained in General Condition 32, a copy of which is included.

#### COMMENTS

The Nationwide permits provide a simplified, expeditious means of project authorization under the various authorities of the Corps of Engineers. We encourage prospective permit applicants to consider the advantages of nationwide permit authorization during the preliminary design of their projects. Assistance and further information regarding all aspects of the Corps of Engineers Regulatory Program may be obtained by contacting the appropriate Corps of Engineers District (the Omaha District has regulatory jurisdiction over the Missouri River, its contiguous wetlands, and Carter Lake. The Rock Island District regulates the remainder of the projects occurring in Iowa.):

US Army engineer District, Rock Island  
Clock Tower Building  
Post Office Box 2004  
Rock Island, Illinois 61204-2004

US Army Engineer District, Omaha  
Wehrspann Regulatory Office  
8901 South 154<sup>th</sup> Street  
Omaha, Nebraska 68138-3635

Telephone: (309) 794-5370

Telephone: (402) 896-0896

#### Nationwide Permits and Conditions

The following is a list of the nationwide permits, authorized by the Chief of Engineers, and published in the Federal Register (82 FR 1860) and. Permittees wishing to conduct activities under the nationwide permits must comply with the conditions published in Section C. The Nationwide Permit General Conditions found in Section C have been reprinted at the end of this Fact Sheet. The parenthetical references (Section 10, Section 404) following each nationwide permit indicate the specific authorities under which that permit is issued.

#### B. Nationwide Permits

**1. Aids to Navigation.** The placement of aids to navigation and regulatory markers that are approved by and installed in accordance with the requirements of the U.S. Coast Guard (see 33 CFR, chapter I, subchapter C, part 66).(Authority: Section 10 of the Rivers and Harbors Act of 1899 (Section 10))

**2. Structures in Artificial Canals.** Structures constructed in artificial canals within principally residential developments where the connection of the canal to a navigable water of the United States has been previously authorized (see 33 CFR 322.5(g)). (Authority: Section 10)

**3. Maintenance.** (a) The repair, rehabilitation, or replacement of any previously authorized, currently serviceable structure or fill, or of any currently serviceable structure or fill authorized by 33 CFR 330.3, provided that the structure or fill is not to be put to uses differing from those uses specified or contemplated for it in the original permit or the most recently authorized modification. Minor deviations in the structure's configuration or filled area, including those due to changes in materials, construction techniques, requirements of other regulatory agencies, or current construction codes or safety standards that are necessary to make the repair, rehabilitation, or replacement are authorized. This NWP also authorizes the removal of previously authorized structures or fills. Any stream channel modification is limited to the minimum necessary for the repair, rehabilitation, or replacement of the structure or fill; such modifications, including the removal of material from the stream channel, must be immediately

adjacent to the project. This NWP also authorizes the removal of accumulated sediment and debris within, and in the immediate vicinity of, the structure or fill. This NWP also authorizes the repair, rehabilitation, or replacement of those structures or fills destroyed or damaged by storms, floods, fire or other discrete events, provided the repair, rehabilitation, or replacement is commenced, or is under contract to commence, within two years of the date of their destruction or damage. In cases of catastrophic events, such as hurricanes or tornadoes, this two-year limit may be waived by the district engineer, provided the permittee can demonstrate funding, contract, or other similar delays.

(b) This NWP also authorizes the removal of accumulated sediments and debris outside the immediate vicinity of existing structures (e.g., bridges, culverted road crossings, water intake structures, etc.). The removal of sediment is limited to the minimum necessary to restore the waterway in the vicinity of the structure to the approximate dimensions that existed when the structure was built, but cannot extend farther than 200 feet in any direction from the structure. This 200 foot limit does not apply to maintenance dredging to remove accumulated sediments blocking or restricting outfall and intake structures or to maintenance dredging to remove accumulated sediments from canals associated with outfall and intake structures. All dredged or excavated materials must be deposited and retained in an area that has no waters of the United States unless otherwise specifically approved by the district engineer under separate authorization.

(c) This NWP also authorizes temporary structures, fills, and work, including the use of temporary mats, necessary to conduct the maintenance activity. Appropriate measures must be taken to maintain normal downstream flows and minimize flooding to the maximum extent practicable, when temporary structures, work, and discharges, including cofferdams, are necessary for construction activities, access fills, or dewatering of construction sites. Temporary fills must consist of materials, and be placed in a manner, that will not be eroded by expected high flows. After conducting the maintenance activity, temporary fills must be removed in their entirety and the affected areas returned to Pre-construction elevations. The areas affected by temporary fills must be revegetated, as appropriate.

(d) This NWP does not authorize maintenance dredging for the primary purpose of navigation. This NWP does not authorize beach restoration. This NWP does not authorize new stream channelization or stream relocation projects.

Notification: For activities authorized by paragraph (b) of this NWP, the permittee must submit a pre-construction notification to the district engineer prior to commencing the activity (see general condition 32). The pre-construction notification must include information regarding the original design capacities and configurations of the outfalls, intakes, small impoundments, and canals. (Authorities: Section 10 of the Rivers and Harbors Act of 1899 and section 404 of the Clean Water Act (Sections 10 and 404))

Note: This NWP authorizes the repair, rehabilitation, or replacement of any previously authorized structure or fill that does not qualify for the Clean Water Act section 404(f) exemption for maintenance.

**4. Fish and Wildlife Harvesting, Enhancement, and Attraction Devices and Activities.** Fish and wildlife harvesting devices and activities such as pound nets, crab traps, crab dredging, eel pots, lobster traps, duck blinds, and clam and oyster digging, fish aggregating devices, and small fish attraction devices such as open water fish concentrators (sea kites, etc.). This NWP does not authorize artificial reefs or impoundments and semi-impoundments of waters of the United States for the culture or holding of motile species such as lobster, or the use of covered oyster trays or clam racks. (Authorities: Sections 10 and 404)

**5. Scientific Measurement Devices.** Devices, whose purpose is to measure and record scientific data, such as staff gages, tide and current gages, meteorological stations, water recording and biological observation devices, water quality testing and improvement devices, and similar structures. Small weirs and flumes constructed primarily to record water quantity and velocity are also authorized provided the discharge is limited to 25 cubic yards. Upon completion of the use of the device to measure and record scientific data, the measuring device and any other structures or fills associated with that device (e.g., foundations, anchors, buoys, lines, etc.) must be removed to the maximum extent practicable and the site restored to pre-construction elevations. (Authorities: Sections 10 and 404)

**6. Survey Activities.** Survey activities, such as core sampling, seismic exploratory operations, plugging of seismic shot holes and other exploratory-type bore holes, exploratory trenching, soil surveys, sampling, sample plots or transects for wetland delineations, and historic resources surveys. For the purposes of this NWP, the term "exploratory trenching" means mechanical land clearing of the upper soil profile to expose bedrock or substrate, for the purpose of mapping or sampling the exposed material. The area in which the exploratory trench is dug must be restored to its pre-construction elevation upon completion of the work and must not drain a water of the United States. In wetlands, the top 6 to 12 inches of the trench should normally be backfilled with topsoil from the trench. This NWP authorizes the construction of temporary pads, provided the discharge does not exceed 1/10-acre in waters of the U.S. Discharges and structures associated with the recovery of historic resources are not authorized by this NWP. Drilling and the discharge of excavated material from test wells for oil and gas exploration are not authorized by this NWP; the plugging of such wells is authorized. Fill placed for roads and other similar activities is not authorized by this NWP. The NWP does not authorize any permanent structures. The discharge of drilling mud and cuttings may require a permit under section 402 of the Clean Water Act. (Authorities: Sections 10 and 404)

**7. Outfall Structures and Associated Intake Structures.** Activities related to the construction or modification of outfall structures and associated intake structures, where the effluent from the outfall is authorized, conditionally authorized, or specifically exempted by, or otherwise in compliance with regulations issued under the National Pollutant Discharge Elimination System Program (section 402 of the Clean Water Act). The construction of intake

structures is not authorized by this NWP, unless they are directly associated with an authorized outfall structure.

Notification: The permittee must submit a pre-construction notification to the district engineer prior to commencing the activity. (See general condition 32.) (Authorities: Sections 10 and 404)

**8. Oil and Gas Structures on the Outer Continental Shelf.** Structures for the exploration, production, and transportation of oil, gas, and minerals on the outer continental shelf within areas leased for such purposes by the Department of the Interior, Bureau of Ocean Energy Management. Such structures shall not be placed within the limits of any designated shipping safety fairway or traffic separation scheme, except temporary anchors that comply with the fairway regulations in 33 CFR 322.5(l). The district engineer will review such proposals to ensure compliance with the provisions of the fairway regulations in 33 CFR 322.5(l). Any Corps review under this NWP will be limited to the effects on navigation and national security in accordance with 33 CFR 322.5(f), as well as 33 CFR 322.5(l) and 33 CFR part 334. Such structures will not be placed in established danger zones or restricted areas as designated in 33 CFR part 334, nor will such structures be permitted in EPA or Corps-designated dredged material disposal areas.

Notification: The permittee must submit a pre-construction notification to the district engineer prior to commencing the activity. (See general condition 32.)(Authority: Section 10)

**9. Structures in Fleeting and Anchorage Areas.** Structures, buoys, floats, and other devices placed within anchorage or fleeting areas to facilitate moorage of vessels where such areas have been established for that purpose. (Authority: Section 10)

**10. Mooring Buoys.** Non-commercial, single-boat, mooring buoys. (Authority: Section 10)

**11. Temporary Recreational Structures.** Temporary buoys, markers, small floating docks, and similar structures placed for recreational use during specific events such as water skiing competitions and boat races or seasonal use, provided that such structures are removed within 30 days after use has been discontinued. At Corps of Engineers reservoirs, the reservoir managers must approve each buoy or marker individually. (Authority: Section 10)

**12. Utility Line Activities.** Activities required for the construction, maintenance, repair, and removal of utility lines and associated facilities in waters of the United States, provided the activity does not result in the loss of greater than 1/2-acre of waters of the United States for each single and complete project. Utility lines: This NWP authorizes discharges of dredged or fill material into waters of the United States and structures or work in navigable waters for crossings of those waters associated with the construction, maintenance, or repair of utility lines, including outfall and intake structures. There must be no change in pre-construction contours of waters of the United States. A "utility line" is defined as any pipe or pipeline for the transportation of any gaseous, liquid, liquescent, or slurry substance, for any purpose, and any cable, line, or wire for the transmission for any purpose of electrical energy, telephone, and telegraph messages, and internet, radio, and television communication. The term "utility line" does not include activities that drain a water of the United States, such as drainage tile or french drains, but it does apply to pipes conveying drainage from another area. Material resulting from trench excavation may be temporarily sidecast into waters of the United States for no more than three months, provided the material is not placed in such a manner that it is dispersed by currents or other forces. The district engineer may extend the period of temporary side casting for no more than a total of 180 days, where appropriate. In wetlands, the top 6 to 12 inches of the trench should normally be backfilled with topsoil from the trench. The trench cannot be constructed or backfilled in such a manner as to drain waters of the United States (e.g., backfilling with extensive gravel layers, creating a french drain effect). Any exposed slopes and stream banks must be stabilized immediately upon completion of the utility line crossing of each waterbody.

Utility line substations: This NWP authorizes the construction, maintenance, or expansion of substation facilities associated with a power line or utility line in non-tidal waters of the United States, provided the activity, in combination with all other activities included in one single and complete project, does not result in the loss of greater than 1/2-acre of waters of the United States. This NWP does not authorize discharges into non-tidal wetlands adjacent to tidal waters of the United States to construct, maintain, or expand substation facilities. Foundations for overhead utility line towers, poles, and anchors: This NWP authorizes the construction or maintenance of foundations for overhead utility line towers, poles, and anchors in all waters of the United States, provided the foundations are the minimum size necessary and separate footings for each tower leg (rather than a larger single pad) are used where feasible.

Access roads: This NWP authorizes the construction of access roads for the construction and maintenance of utility lines, including overhead power lines and utility line substations, in non-tidal waters of the United States, provided the activity, in combination with all other activities included in one single and complete project, does not cause the loss of greater than 1/2-acre of non-tidal waters of the United States. This NWP does not authorize discharges into non-tidal wetlands adjacent to tidal waters for access roads. Access roads must be the minimum width necessary (see Note 2, below). Access roads must be constructed so that the length of the road minimizes any adverse effects on waters of the United States and must be as near as possible to pre-construction contours and elevations (e.g., at grade corduroy roads or geotextile/gravel roads). Access roads constructed above pre-construction contours and elevations in waters of the United States must be properly bridged or culverted to maintain surface flows.

This NWP may authorize utility lines in or affecting navigable waters of the United States even if there is no associated discharge of dredged or fill material (See 33 CFR part 322). Overhead utility lines constructed over section 10 waters and utility lines that are routed in or under section 10 waters without a discharge of dredged or fill material require a section 10 permit.

This NWP authorizes, to the extent that Department of the Army authorization is required, temporary structures, fills, and work necessary for the remediation of inadvertent returns of drilling fluids to waters of the United States through sub-soil fissures or fractures that might occur during horizontal directional drilling activities conducted for the purpose of installing or replacing utility lines. These remediation activities must be done as soon as practicable, to restore the affected waterbody. District engineers may add special conditions to this NWP to require a remediation plan for addressing inadvertent returns of drilling fluids to waters of the United States during horizontal directional drilling activities conducted for the purpose of installing or replacing utility lines.

This NWP also authorizes temporary structures, fills, and work, including the use of temporary mats, necessary to conduct the utility line activity. Appropriate measures must be taken to maintain normal downstream flows and minimize flooding to the maximum extent practicable, when temporary structures, work, and discharges, including cofferdams, are necessary for construction activities, access fills, or dewatering of construction sites. Temporary fills must consist of materials, and be placed in a manner, that will not be eroded by expected high flows. After construction, temporary fills must be removed in their entirety and the affected areas returned to Pre-construction elevations. The areas affected by temporary fills must be revegetated, as appropriate.

Notification: The permittee must submit a pre-construction notification to the district engineer prior to commencing the activity if any of the following criteria are met: (1) The activity involves mechanized land clearing in a forested wetland for the utility line right-of-way; (2) a section 10 permit is required; (3) the utility line in waters of the United States, excluding overhead lines, exceeds 500 feet; (4) the utility line is placed within a jurisdictional area (i.e., water of the United States), and it runs parallel to or along a stream bed that is within that jurisdictional area; (5) discharges that result in the loss of greater than 1/10- acre of waters of the United States; (6) permanent access roads are constructed above grade in waters of the United States for a distance of more than 500 feet; or (7) permanent access roads are constructed in waters of the United States with impervious materials. (See general condition 32.) (Authorities: Sections 10 and 404)

Note 1: Where the utility line is constructed or installed in navigable waters of the United States (i.e., section 10 waters) within the coastal United States, the Great Lakes, and United States territories, a copy of the NWP verification will be sent by the Corps to the National Oceanic and Atmospheric Administration (NOAA), National Ocean Service (NOS), for charting the utility line to protect navigation.

Note 2: For utility line activities crossing a single waterbody more than one time at separate and distant locations, or multiple waterbodies at separate and distant locations, each crossing is considered a single and complete project for purposes of NWP authorization. Utility line activities must comply with 33 CFR 330.6(d).

Note 3: Utility lines consisting of aerial electric power transmission lines crossing navigable waters of the United States (which are defined at 33 CFR part 329) must comply with the applicable minimum clearances specified in 33 CFR 322.5(i).

Note 4: Access roads used for both construction and maintenance may be authorized, provided they meet the terms and conditions of this NWP. Access roads used solely for construction of the utility line must be removed upon completion of the work, in accordance with the requirements for temporary fills.

Note 5: Pipes or pipelines used to transport gaseous, liquid, liquescent, or slurry substances over navigable waters of the United States are considered to be bridges, not utility lines, and may require a permit from the U.S. Coast Guard pursuant to section 9 of the Rivers and Harbors Act of 1899. However, any discharges of dredged or fill material into waters of the United States associated with such pipelines will require a section 404 permit (see NWP 15).

Note 6: This NWP authorizes utility line maintenance and repair activities that do not qualify for the Clean Water Act section 404(f) exemption for maintenance of currently serviceable fills or fill structures.

Note 7: For overhead utility lines authorized by this NWP, a copy of the PCN and NWP verification will be provided to the Department of Defense Siting Clearinghouse, which will evaluate potential effects on military activities.

Note 8: For NWP 12 activities that require pre-construction notification, the PCN must include any other NWP(s), regional general permit(s), or individual permit(s) used or intended to be used to authorize any part of the proposed project or any related activity, including other separate and distant crossings that require Department of the Army authorization but do not require Pre-construction notification (see paragraph (b) of general condition 32). The district engineer will evaluate the PCN in accordance with Section D, "District Engineer's Decision." The district engineer may require mitigation to ensure that the authorized activity results in no more than minimal individual and cumulative adverse environmental effects (see general condition 23).

**13. Bank Stabilization.** Bank stabilization activities necessary for erosion control or prevention, such as vegetative stabilization, bioengineering, sills, rip rap, revetment, gabion baskets, stream barbs, and bulkheads, or combinations of bank stabilization techniques, provided the activity meets all of the following criteria:

- (a) No material is placed in excess of the minimum needed for erosion protection;
- (b) The activity is no more than 500 feet in length along the bank, unless the district engineer waives this criterion by making a written determination concluding that the discharge will result in no more than minimal adverse environmental effects (an exception is for bulkheads—the district engineer cannot issue a waiver for a bulkhead that is greater than 1,000 feet in length along the bank);
- (c) The activity will not exceed an average of one cubic yard per running foot, as measured along the length of the treated bank, below the plane of the ordinary high water mark or the high tide line, unless the district engineer waives this criterion by making a written determination concluding that the discharge will result in no more than minimal adverse environmental effects;

- (d) The activity does not involve discharges of dredged or fill material into special aquatic sites, unless the district engineer waives this criterion by making a written determination concluding that the discharge will result in no more than minimal adverse environmental effects;
- (e) No material is of a type, or is placed in any location, or in any manner, that will impair surface water flow into or out of any waters of the United States;
- (f) No material is placed in a manner that will be eroded by normal or expected high flows (properly anchored native trees and treetops may be used in low energy areas);
- (g) Native plants appropriate for current site conditions, including salinity, must be used for bioengineering or vegetative bank stabilization;
- (h) The activity is not a stream channelization activity; and
- (i) The activity must be properly maintained, which may require repairing it after severe storms or erosion events. This NWP authorizes those maintenance and repair activities if they require authorization. This NWP also authorizes temporary structures, fills, and work, including the use of temporary mats, necessary to construct the bank stabilization activity. Appropriate measures must be taken to maintain normal downstream flows and minimize flooding to the maximum extent practicable, when temporary structures, work, and discharges, including cofferdams, are necessary for construction activities, access fills, or dewatering of construction sites. Temporary fills must consist of materials, and be placed in a manner, that will not be eroded by expected high flows. After construction, temporary fills must be removed in their entirety and the affected areas returned to pre-construction elevations. The areas affected by temporary fills must be revegetated, as appropriate.

Invasive plant species shall not be used for bioengineering or vegetative bank stabilization.

Notification: The permittee must submit a pre-construction notification to the district engineer prior to commencing the activity if the bank stabilization activity: (1) Involves discharges into special aquatic sites; or (2) is in excess of 500 feet in length; or (3) will involve the discharge of greater than an average of one cubic yard per running foot as measured along the length of the treated bank, below the plane of the ordinary high water mark or the high tide line. (See general condition 32.) (Authorities: Sections 10 and 404)

**14. Linear Transportation Projects.** Activities required for crossings of waters of the United States associated with the construction, expansion, modification, or improvement of linear transportation projects (e.g., roads, highways, railways, trails, airport runways, and taxiways) in waters of the United States. For linear transportation projects in non-tidal waters, the discharge cannot cause the loss of greater than 1/2-acre of waters of the United States. For linear transportation projects in tidal waters, the discharge cannot cause the loss of greater than 1/3-acre of waters of the United States. Any stream channel modification, including bank stabilization, is limited to the minimum necessary to construct or protect the linear transportation project; such modifications must be in the immediate vicinity of the project.

This NWP also authorizes temporary structures, fills, and work, including the use of temporary mats, necessary to construct the linear transportation project. Appropriate measures must be taken to maintain normal downstream flows and minimize flooding to the maximum extent practicable, when temporary structures, work, and discharges, including cofferdams, are necessary for construction activities, access fills, or dewatering of construction sites. Temporary fills must consist of materials, and be placed in a manner, that will not be eroded by expected high flows. Temporary fills must be removed in their entirety and the affected areas returned to Pre-construction elevations. The areas affected by temporary fills must be revegetated, as appropriate.

This NWP cannot be used to authorize non-linear features commonly associated with transportation projects, such as vehicle maintenance or storage buildings, parking lots, train stations, or aircraft hangars.

Notification: The permittee must submit a pre-construction notification to the district engineer prior to commencing the activity if: (1) The loss of waters of the United States exceeds 1/10-acre; or (2) there is a discharge in a special aquatic site, including wetlands. (See general condition 32.) (Authorities: Sections 10 and 404)

Note 1: For linear transportation projects crossing a single waterbody more than one time at separate and distant locations, or multiple waterbodies at separate and distant locations, each crossing is considered a single and complete project for purposes of NWP authorization. Linear transportation projects must comply with 33 CFR 330.6(d).

Note 2: Some discharges for the construction of farm roads or forest roads, or temporary roads for moving mining equipment, may qualify for an exemption under section 404(f) of the Clean Water Act (see 33 CFR 323.4).

Note 3: For NWP 14 activities that require pre-construction notification, the PCN must include any other NWP(s), regional general permit(s), or individual permit(s) used or intended to be used to authorize any part of the proposed project or any related activity, including other separate and distant crossings that require Department of the Army authorization but do not require Pre-construction notification (see paragraph (b) of general condition 32). The district engineer will evaluate the PCN in accordance with Section D, "District Engineer's Decision." The district engineer may require mitigation to ensure that the authorized activity results in no more than minimal individual and cumulative adverse environmental effects (see general condition 23).

**15. U.S. Coast Guard Approved Bridges.** Discharges of dredged or fill material incidental to the construction of a bridge across navigable waters of the United States, including cofferdams, abutments, foundation seals, piers, and temporary construction and access fills, provided the construction of the bridge structure has been authorized by the U.S. Coast Guard under Section 9 of the Rivers and Harbors Act of 1899 or other applicable laws. Causeways and approach fills are not included in this NWP and will require a separate section 404 permit. (Authority: Section 404 of the Clean Water Act (Section 404))



**16. Return Water From Upland Contained Disposal Areas.** Return water from an upland contained dredged material disposal area. The return water from a contained disposal area is administratively defined as a discharge of dredged material by 33 CFR 323.2(d), even though the disposal itself occurs in an area that has no waters of the United States and does not require a section 404 permit. This NWP satisfies the technical requirement for a section 404 permit for the return water where the quality of the return water is controlled by the state through the section 401 certification procedures. The dredging activity may require a section 404 permit (33 CFR 323.2(d)), and will require a section 10 permit if located in navigable waters of the United States. (Authority: Section 404)

**17. Hydropower Projects.** Discharges of dredged or fill material associated with hydropower projects having: (a) Less than 5000 kW of total generating capacity at existing reservoirs, where the project, including the fill, is licensed by the Federal Energy Regulatory Commission (FERC) under the Federal Power Act of 1920, as amended; or (b) a licensing exemption granted by the FERC pursuant to section 408 of the Energy Security Act of 1980 (16 U.S.C. 2705 and 2708) and section 30 of the Federal Power Act, as amended.

Notification: The permittee must submit a pre-construction notification to the district engineer prior to commencing the activity. (See general condition 32.) (Authority: Section 404)

**18. Minor Discharges.** Minor discharges of dredged or fill material into all waters of the United States, provided the activity meets all of the following criteria:

- (a) The quantity of discharged material and the volume of area excavated do not exceed 25 cubic yards below the plane of the ordinary high water mark or the high tide line;
- (b) The discharge will not cause the loss of more than 1/10-acre of waters of the United States; and
- (c) The discharge is not placed for the purpose of a stream diversion.

Notification: The permittee must submit a pre-construction notification to the district engineer prior to commencing the activity if: (1) The discharge or the volume of area excavated exceeds 10 cubic yards below the plane of the ordinary high water mark or the high tide line, or (2) the discharge is in a special aquatic site, including wetlands. (See general condition 32.) (Authorities: Sections 10 and 404)

**19. Minor Dredging.** Dredging of no more than 25 cubic yards below the plane of the ordinary high water mark or the mean high water mark from navigable waters of the United States (i.e., section 10 waters). This NWP does not authorize the dredging or degradation through siltation of coral reefs, sites that support submerged aquatic vegetation (including sites where submerged aquatic vegetation is documented to exist but may not be present in a given year), anadromous fish spawning areas, or wetlands, or the connection of canals or other artificial waterways to navigable waters of the United States (see 33 CFR 322.5(g)). All dredged material must be deposited and retained in an area that has no waters of the United States unless otherwise specifically approved by the district engineer under separate authorization. (Authorities: Sections 10 and 404)

**20. Response Operations for Oil and Hazardous Substances.** Activities conducted in response to a discharge or release of oil or hazardous substances that are subject to the National Oil and Hazardous Substances Pollution Contingency Plan (40 CFR part 300) including containment, cleanup, and mitigation efforts, provided that the activities are done under either: (1) The Spill Control and Countermeasure Plan required by 40 CFR 112.3; (2) the direction or oversight of the federal on-scene coordinator designated by 40 CFR part 300; or (3) any approved existing state, regional or local contingency plan provided that the Regional Response Team (if one exists in the area) concurs with the proposed response efforts. This NWP also authorizes activities required for the cleanup of oil releases in waters of the United States from electrical equipment that are governed by EPA's polychlorinated biphenyl spill response regulations at 40 CFR part 761. This NWP also authorizes the use of temporary structures and fills in waters of the U.S. for spill response training exercises. (Authorities: Sections 10 and 404)

**21. Surface Coal Mining Activities.** Discharges of dredged or fill material into waters of the United States associated with surface coal mining and reclamation operations, provided the following criteria are met:

- (a) The activities are already authorized, or are currently being processed by states with approved programs under Title V of the Surface Mining Control and Reclamation Act of 1977 or as part of an integrated permit processing procedure by the Department of the Interior, Office of Surface Mining Reclamation and Enforcement;
- (b) The discharge must not cause the loss of greater than 1/2-acre of non-tidal waters of the United States. The discharge must not cause the loss of more than 300 linear feet of stream bed, unless for intermittent and ephemeral stream beds the district engineer waives the 300 linear foot limit by making a written determination concluding that the discharge will result in no more than minimal individual and cumulative adverse environmental effects. The loss of stream bed plus any other losses of jurisdictional wetlands and waters caused by the NWP activity cannot exceed 1/2-acre. This NWP does not authorize discharges into tidal waters or non-tidal wetlands adjacent to tidal waters; and
- (c) The discharge is not associated with the construction of valley fills. A "valley fill" is a fill structure that is typically constructed within valleys associated with steep, mountainous terrain, associated with surface coal mining activities.

Notification: The permittee must submit a pre-construction notification to the district engineer and receive written authorization prior to commencing the activity. (See general condition 32.) (Authorities: Sections 10 and 404)

**22. Removal of Vessels.** Temporary structures or minor discharges of dredged or fill material required for the removal of wrecked, abandoned, or disabled vessels, or the removal of man-made obstructions to navigation. This NWP does not authorize maintenance dredging, shoal removal, or riverbank snagging.

Notification: The permittee must submit a pre-construction notification to the district engineer prior to commencing the activity if: (1) The vessel is listed or eligible for listing in the National Register of Historic Places; or (2) the activity is conducted in a special aquatic site, including coral reefs and wetlands. (See general condition 32.) If condition 1 above is triggered, the permittee cannot commence the activity until informed by the district engineer that compliance with the "Historic Properties" general condition is completed. (Authorities: Sections 10 and 404)

Note 1: If a removed vessel is disposed of in waters of the United States, a permit from the U.S. EPA may be required (see 40 CFR 229.3). If a Department of the Army permit is required for vessel disposal in waters of the United States, separate authorization will be required.

Note 2: Compliance with general condition 18, Endangered Species, and general condition 20, Historic Properties, is required for all NWPs. The concern with historic properties is emphasized in the notification requirements for this NWP because of the possibility that shipwrecks may be historic properties.

**23. Approved Categorical Exclusions.** Activities undertaken, assisted, authorized, regulated, funded, or financed, in whole or in part, by another Federal agency or department where:

- (a) That agency or department has determined, pursuant to the Council on Environmental Quality's implementing regulations for the National Environmental Policy Act (40 CFR part 1500 et seq.), that the activity is categorically excluded from the requirement to prepare an environmental impact statement or environmental assessment analysis, because it is included within a category of actions which neither individually nor cumulatively have a significant effect on the human environment; and
- (b) The Office of the Chief of Engineers (Attn: CECW-CO) has concurred with that agency's or department's determination that the activity is categorically excluded and approved the activity for authorization under NWP 23.

The Office of the Chief of Engineers may require additional conditions, including pre-construction notification, for authorization of an agency's categorical exclusions under this NWP.

Notification: Certain categorical exclusions approved for authorization under this NWP require the permittee to submit a pre-construction notification to the district engineer prior to commencing the activity (see general condition 32). The activities that require pre-construction notification are listed in the appropriate Regulatory Guidance Letters. (Authorities: Sections 10 and 404)

Note: The agency or department may submit an application for an activity believed to be categorically excluded to the Office of the Chief of Engineers (Attn: CECW-CO). Prior to approval for authorization under this NWP of any agency's activity, the Office of the Chief of Engineers will solicit public comment. As of the date of issuance of this NWP, agencies with approved categorical exclusions are: the Bureau of Reclamation, Federal Highway Administration, and U.S. Coast Guard. Activities approved for authorization under this NWP as of the date of this notice are found in Corps Regulatory Guidance Letter 05-07, which is available at: <http://www.usace.army.mil/Portals/2/docs/civilworks/RGLS/rgl05-07.pdf>. Any future approved categorical exclusions will be announced in Regulatory Guidance Letters and posted on this same Web site.

**24. Indian Tribe or State Administered Section 404 Programs.** Any activity permitted by a state or Indian Tribe administering its own section 404 permit program pursuant to 33 U.S.C. 1344(g)-(1) is permitted pursuant to section 10 of the Rivers and Harbors Act of 1899. (Authority: Section 10)

Note 1: As of the date of the promulgation of this NWP, only New Jersey and Michigan administer their own section 404 permit programs.

Note 2: Those activities that do not involve an Indian Tribe or State section 404 permit are not included in this NWP, but certain structures will be exempted by Section 154 of Public Law 94-587, 90 Stat. 2917 (33 U.S.C. 591) (see 33 CFR 322.4(b)).

**25. Structural Discharges.** Discharges of material such as concrete, sand, rock, etc., into tightly sealed forms or cells where the material will be used as a structural member for standard pile supported structures, such as bridges, transmission line footings, and walkways, or for general navigation, such as mooring cells, including the excavation of bottom material from within the form prior to the discharge of concrete, sand, rock, etc. This NWP does not authorize filled structural members that would support buildings, building pads, homes, house pads, parking areas, storage areas and other such structures. The structure itself may require a separate section 10 permit if located in navigable waters of the United States. (Authority: Section 404)

**26. [Reserved]**

**27. Aquatic Habitat Restoration, Establishment, and Enhancement Activities.** Activities in waters of the United States associated with the restoration, enhancement, and establishment of tidal and non-tidal wetlands and riparian areas, the restoration and enhancement of non-tidal streams and other non-tidal open waters, and the rehabilitation or enhancement of tidal streams, tidal wetlands, and tidal open waters, provided those activities result in net increases in aquatic resource functions and services.

To be authorized by this NWP, the aquatic habitat restoration, enhancement, or establishment activity must be planned, designed, and implemented so that it results in aquatic habitat that resembles an ecological reference. An ecological reference may be based on the characteristics of an intact aquatic habitat or riparian area of the same type that exists in the region. An ecological reference may be based on a conceptual model developed from regional ecological knowledge of the target aquatic habitat type or riparian area.

To the extent that a Corps permit is required, activities authorized by this NWP include, but are not limited to: The removal of accumulated sediments; the installation, removal, and maintenance of small water control structures, dikes, and berms, as well as discharges of dredged or fill material to restore appropriate stream channel configurations after small water control structures, dikes, and berms, are removed; the installation of current deflectors; the enhancement, rehabilitation, or re-establishment of riffle and pool stream structure; the placement of in-stream habitat structures; modifications of the stream bed and/or banks to enhance, rehabilitate, or re-establish stream meanders; the removal of stream barriers, such as undersized culverts, fords, and grade control structures; the backfilling of artificial channels; the removal of existing drainage structures, such as drain tiles, and the filling, blocking, or reshaping of drainage ditches to restore wetland hydrology; the installation of structures or fills necessary to restore or enhance wetland or stream hydrology; the construction of small nesting islands; the construction of open water areas; the construction of oyster habitat over unvegetated bottom in tidal waters; shellfish seeding; activities needed to reestablish vegetation, including plowing or discing for seed bed preparation and the planting of appropriate wetland species; re-establishment of submerged aquatic vegetation in areas where those plant communities previously existed; re-establishment of tidal wetlands in tidal waters where those wetlands previously existed; mechanized land clearing to remove non-native invasive, exotic, or nuisance vegetation; and other related activities. Only native plant species should be planted at the site.

This NWP authorizes the relocation of non-tidal waters, including non-tidal wetlands and streams, on the project site provided there are net increases in aquatic resource functions and services.

Except for the relocation of non-tidal waters on the project site, this NWP does not authorize the conversion of a stream or natural wetlands to another aquatic habitat type (e.g., the conversion of a stream to wetland or vice versa) or uplands. Changes in wetland plant communities that occur when wetland hydrology is more fully restored during wetland rehabilitation activities are not considered a conversion to another aquatic habitat type. This NWP does not authorize stream channelization. This NWP does not authorize the relocation of tidal waters or the conversion of tidal waters, including tidal wetlands, to other aquatic uses, such as the conversion of tidal wetlands into open water impoundments.

Compensatory mitigation is not required for activities authorized by this NWP since these activities must result in net increases in aquatic resource functions and services.

Reversion. For enhancement, restoration, and establishment activities conducted: (1) In accordance with the terms and conditions of a binding stream or wetland enhancement or restoration agreement, or a wetland establishment agreement, between the landowner and the U.S. Fish and Wildlife Service (FWS), the Natural Resources Conservation Service (NRCS), the Farm Service Agency (FSA), the National Marine Fisheries Service (NMFS), the National Ocean Service (NOS), U.S. Forest Service (USFS), or their designated state cooperating agencies; (2) as voluntary wetland restoration, enhancement, and establishment actions documented by the NRCS or USDA Technical Service Provider pursuant to NRCS Field Office Technical Guide standards; or (3) on reclaimed surface coal mine lands, in accordance with a Surface Mining Control and Reclamation Act permit issued by the Office of Surface Mining Reclamation and Enforcement (OSMRE) or the applicable state agency, this NWP also authorizes any future discharge of dredged or fill material associated with the reversion of the area to its documented prior condition and use (i.e., prior to the restoration, enhancement, or establishment activities). The reversion must occur within five years after expiration of a limited term wetland restoration or establishment agreement or permit, and is authorized in these circumstances even if the discharge occurs after this NWP expires. The five-year reversion limit does not apply to agreements without time limits reached between the landowner and the FWS, NRCS, FSA, NMFS, NOS, USFS, or an appropriate state cooperating agency. This NWP also authorizes discharges of dredged or fill material in waters of the United States for the reversion of wetlands that were restored, enhanced, or established on prior-converted cropland or on uplands, in accordance with a binding agreement between the landowner and NRCS, FSA, FWS, or their designated state cooperating agencies (even though the restoration, enhancement, or establishment activity did not require a section 404 permit). The prior condition will be documented in the original agreement or permit, and the determination of return to prior conditions will be made by the Federal agency or appropriate state agency executing the agreement or permit. Before conducting any reversion activity the permittee or the appropriate Federal or state agency must notify the district engineer and include the documentation of the prior condition. Once an area has reverted to its prior physical condition, it will be subject to whatever the Corps Regulatory requirements are applicable to that type of land at the time. The requirement that the activity results in a net increase in aquatic resource functions and services does not apply to reversion activities meeting the above conditions. Except for the activities described above, this NWP does not authorize any future discharge of dredged or fill material associated with the reversion of the area to its prior condition. In such cases a separate permit would be required for any reversion.

Reporting. For those activities that do not require pre-construction notification, the permittee must submit to the district engineer a copy of: (1) The binding stream enhancement or restoration agreement or wetland enhancement, restoration, or establishment agreement, or a project description, including project plans and location map; (2) the NRCS or USDA Technical Service Provider documentation for the voluntary stream enhancement or restoration action or wetland restoration, enhancement, or establishment action; or (3) the SMCRA permit issued by OSMRE or the applicable state agency. The report must also include information on baseline ecological conditions on the project site, such as a delineation of wetlands, streams, and/or other aquatic habitats. These documents must be submitted to the district engineer at least 30 days prior to commencing activities in waters of the United States authorized by this NWP.

Notification: The permittee must submit a pre-construction notification to the district engineer prior to commencing any activity (see general condition 32), except for the following activities:

- (1) Activities conducted on non-Federal public lands and private lands, in accordance with the terms and conditions of a binding stream enhancement or restoration agreement or wetland enhancement, restoration, or establishment agreement between the landowner and the FWS, NRCS, FSA, NMFS, NOS, USFS or their designated state cooperating agencies;
- (2) Voluntary stream or wetland restoration or enhancement action, or wetland establishment action, documented by the NRCS or USDA Technical Service Provider pursuant to NRCS Field Office Technical Guide standards; or
- (3) The reclamation of surface coal mine lands, in accordance with an SMCRA permit issued by the OSMRE or the applicable state agency.

However, the permittee must submit a copy of the appropriate documentation to the district engineer to fulfill the reporting requirement. (Authorities: Sections 10 and 404)

Note: This NWP can be used to authorize compensatory mitigation projects, including mitigation banks and in-lieu fee projects. However, this NWP does not authorize the reversion of an area used for a compensatory mitigation project to its prior condition, since compensatory mitigation is generally intended to be permanent.

**28. Modifications of Existing Marinas.** Reconfiguration of existing docking facilities within an authorized marina area. No dredging, additional slips, dock spaces, or expansion of any kind within waters of the United States is authorized by this NWP. (Authority: Section 10)

**29. Residential Developments.** Discharges of dredged or fill material into non-tidal waters of the United States for the construction or expansion of a single residence, a multiple unit residential development, or a residential subdivision. This NWP authorizes the construction of building foundations and building pads and attendant features that are necessary for the use of the residence or residential development. Attendant features may include but are not limited to roads, parking lots, garages, yards, utility lines, storm water management facilities, septic fields, and recreation facilities such as playgrounds, playing fields, and golf courses (provided the golf course is an integral part of the residential development).

The discharge must not cause the loss of greater than 1/2-acre of non-tidal waters of the United States. The discharge must not cause the loss of more than 300 linear feet of stream bed, unless for intermittent and ephemeral stream beds the district engineer waives the 300 linear foot limit by making a written determination concluding that the discharge will result in no more than minimal adverse environmental effects. This NWP does not authorize discharges into non-tidal wetlands adjacent to tidal waters. The loss of stream bed plus any other losses of jurisdictional wetlands and waters caused by the NWP activity cannot exceed 1/2-acre.

Subdivisions: For residential subdivisions, the aggregate total loss of waters of United States authorized by this NWP cannot exceed 1/2-acre. This includes any loss of waters of the United States associated with development of individual subdivision lots.

Notification: The permittee must submit a pre-construction notification to the district engineer prior to commencing the activity. (See general condition 32.) (Authorities: Sections 10 and 404)

**30. Moist Soil Management for Wildlife.** Discharges of dredged or fill material into non-tidal waters of the United States and maintenance activities that are associated with moist soil management for wildlife for the purpose of continuing ongoing, site-specific, wildlife management activities where soil manipulation is used to manage habitat and feeding areas for wildlife. Such activities include, but are not limited to, plowing or discing to impede succession, preparing seed beds, or establishing fire breaks. Sufficient riparian areas must be maintained adjacent to all open water bodies, including streams, to preclude water quality degradation due to erosion and sedimentation. This NWP does not authorize the construction of new dikes, roads, water control structures, or similar features associated with the management areas. The activity must not result in a net loss of aquatic resource functions and services. This NWP does not authorize the conversion of wetlands to uplands, impoundments, or other open water bodies. (Authority: Section 404)

Note: The repair, maintenance, or replacement of existing water control structures or the repair or maintenance of dikes may be authorized by NWP 3. Some such activities may qualify for an exemption under section 404(f) of the Clean Water Act (see 33 CFR 323.4).

**31. Maintenance of Existing Flood Control Facilities.** Discharges of dredged or fill material resulting from activities associated with the maintenance of existing flood control facilities, including debris basins, retention/ detention basins, levees, and channels that: (i) Were previously authorized by the Corps by individual permit, general permit, or 33 CFR 330.3, or did not require a permit at the time they were constructed, or (ii) were constructed by the Corps and transferred to a non-Federal sponsor for operation and maintenance. Activities authorized by this NWP are limited to those resulting from maintenance activities that are conducted within the 'maintenance baseline,' as described in the definition below. Discharges of dredged or fill materials associated with maintenance activities in flood control facilities in any watercourse that have previously been determined to be within the maintenance baseline are authorized under this NWP. To the extent that a Corps permit is required, this NWP authorizes the removal of vegetation from levees associated with the flood control project. This NWP does not authorize the removal of sediment and associated vegetation from natural water courses except when these activities have been included in the maintenance baseline. All dredged and excavated material must be deposited and retained in an area that has no waters of the United States unless otherwise specifically approved by the district engineer under separate authorization. Proper sediment controls must be used.

Maintenance Baseline: The maintenance baseline is a description of the physical characteristics (e.g., depth, width, length, location, configuration, or design flood capacity, etc.) of a flood control project within which maintenance activities are normally authorized by NWP 31, subject to any case-specific conditions required by the district engineer. The district

engineer will approve the maintenance baseline based on the approved or constructed capacity of the flood control facility, whichever is smaller, including any areas where there are no constructed channels but which are part of the facility. The prospective permittee will provide documentation of the physical characteristics of the flood control facility (which will normally consist of as-built or approved drawings) and documentation of the approved and constructed design capacities of the flood control facility. If no evidence of the constructed capacity exists, the approved capacity will be used. The documentation will also include best management practices to ensure that the adverse environmental impacts caused by the maintenance activities are no more than minimal, especially in maintenance areas where there are no constructed channels. (The Corps may request maintenance records in areas where there has not been recent maintenance.) Revocation or modification of the final determination of the maintenance baseline can only be done in accordance with 33 CFR 330.5. Except in emergencies as described below, this NWP cannot be used until the district engineer approves the maintenance baseline and determines the need for mitigation and any regional or activity-specific conditions. Once determined, the maintenance baseline will remain valid for any subsequent reissuance of this NWP. This NWP does not authorize maintenance of a flood control facility that has been abandoned. A flood control facility will be considered abandoned if it has operated at a significantly reduced capacity without needed maintenance being accomplished in a timely manner. A flood control facility will not be considered abandoned if the prospective permittee is in the process of obtaining other authorizations or approvals required for maintenance activities and is experiencing delays in obtaining those authorizations or approvals.

**Mitigation:** The district engineer will determine any required mitigation one-time only for impacts associated with maintenance work at the same time that the maintenance baseline is approved. Such one-time mitigation will be required when necessary to ensure that adverse environmental effects are no more than minimal, both individually and cumulatively. Such mitigation will only be required once for any specific reach of a flood control project. However, if one-time mitigation is required for impacts associated with maintenance activities, the district engineer will not delay needed maintenance, provided the district engineer and the permittee establish a schedule for identification, approval, development, construction and completion of any such required mitigation. Once the one-time mitigation described above has been completed, or a determination made that mitigation is not required, no further mitigation will be required for maintenance activities within the maintenance baseline (see Note, below). In determining appropriate mitigation, the district engineer will give special consideration to natural water courses that have been included in the maintenance baseline and require mitigation and/or best management practices as appropriate.

**Emergency Situations:** In emergency situations, this NWP may be used to authorize maintenance activities in flood control facilities for which no maintenance baseline has been approved. Emergency situations are those which would result in an unacceptable hazard to life, a significant loss of property, or an immediate, unforeseen, and significant economic hardship if action is not taken before a maintenance baseline can be approved. In such situations, the determination of mitigation requirements, if any, may be deferred until the emergency has been resolved. Once the emergency has ended, a maintenance baseline must be established expeditiously, and mitigation, including mitigation for maintenance conducted during the emergency, must be required as appropriate.

**Notification:** The permittee must submit a pre-construction notification to the district engineer before any maintenance work is conducted (see general condition 32). The Pre-construction notification may be for activity-specific maintenance or for maintenance of the entire flood control facility by submitting a five-year (or less) maintenance plan. The Pre-construction notification must include a description of the maintenance baseline and the disposal site for dredged or excavated material. (Authorities: Sections 10 and 404)

**Note:** If the maintenance baseline was approved by the district engineer under a prior version of NWP 31, and the district engineer imposed the one-time compensatory mitigation requirement on maintenance for a specific reach of a flood control project authorized by that prior version of NWP 31, during the period this version of NWP 31 is in effect (March 19, 2017, to March 18, 2022) the district engineer will not require additional compensatory mitigation for maintenance activities authorized by this NWP in that specific reach of the flood control project.

**32. Completed Enforcement Actions.** Any structure, work, or discharge of dredged or fill material remaining in place or undertaken for mitigation, restoration, or environmental benefit in compliance with either:

- i. The terms of a final written Corps non-judicial settlement agreement resolving a violation of Section 404 of the Clean Water Act and/or section 10 of the Rivers and Harbors Act of 1899; or the terms of an EPA 309(a) order on consent resolving a violation of section 404 of the Clean Water Act, provided that:
  - (a) The activities authorized by this NWP cannot adversely affect more than 5 acres of non-tidal waters or 1 acre of tidal waters;
  - (b) The settlement agreement provides for environmental benefits, to an equal or greater degree, than the environmental detriments caused by the unauthorized activity that is authorized by this NWP; and
  - (c) The district engineer issues a verification letter authorizing the activity subject to the terms and conditions of this NWP and the settlement agreement, including a specified completion date; or
- ii. The terms of a final Federal court decision, consent decree, or settlement agreement resulting from an enforcement action brought by the United States under section 404 of the Clean Water Act and/or Section 10 of the Rivers and Harbors Act of 1899; or
- iii. The terms of a final court decision, consent decree, settlement agreement, or non-judicial settlement agreement resulting from a natural resource damage claim brought by a trustee or trustees for natural resources (as defined by the National Contingency Plan at 40 CFR subpart G) under Section 311 of the Clean Water Act, Section 107 of the Comprehensive Environmental Response, Compensation and Liability Act, Section 312 of the National Marine Sanctuaries Act, section 1002 of the Oil Pollution Act of 1990, or the Park System Resource Protection Act at 16

U.S.C. 19jj, to the extent that a Corps permit is required.

Compliance is a condition of the NWP itself; non-compliance of the terms and conditions of an NWP 32 authorization may result in an additional enforcement action (e.g., a Class I civil administrative penalty). Any authorization under this NWP is automatically revoked if the permittee does not comply with the terms of this NWP or the terms of the court decision, consent decree, or judicial/non-judicial settlement agreement. This NWP does not apply to any activities occurring after the date of the decision, decree, or agreement that are not for the purpose of mitigation, restoration, or environmental benefit. Before reaching any settlement agreement, the Corps will ensure compliance with the provisions of 33 CFR part 326 and 33 CFR 330.6(d)(2) and (e). (Authorities: Sections 10 and 404)

**33. Temporary Construction, Access, and Dewatering.** Temporary structures, work, and discharges, including cofferdams, necessary for construction activities or access fills or dewatering of construction sites, provided that the associated primary activity is authorized by the Corps of Engineers or the U.S. Coast Guard. This NWP also authorizes temporary structures, work, and discharges, including cofferdams, necessary for construction activities not otherwise subject to the Corps or U.S. Coast Guard permit requirements. Appropriate measures must be taken to maintain near normal downstream flows and to minimize flooding. Fill must consist of materials, and be placed in a manner, that will not be eroded by expected high flows. The use of dredged material may be allowed if the district engineer determines that it will not cause more than minimal adverse environmental effects. Following completion of construction, temporary fill must be entirely removed to an area that has no waters of the United States, dredged material must be returned to its original location, and the affected areas must be restored to pre-construction elevations. The affected areas must also be revegetated, as appropriate. This permit does not authorize the use of cofferdams to dewater wetlands or other aquatic areas to change their use. Structures left in place after construction is completed require a separate section 10 permit if located in navigable waters of the United States. (See 33 CFR part 322.)

Notification: The permittee must submit a pre-construction notification to the district engineer prior to commencing the activity if the activity is conducted in navigable waters of the United States (i.e., section 10 waters) (see general condition 32). The pre-construction notification must include a restoration plan showing how all temporary fills and structures will be removed and the area restored to pre-project conditions. (Authorities: Sections 10 and 404)

**34. Cranberry Production Activities.** Discharges of dredged or fill material for dikes, berms, pumps, water control structures or leveling of cranberry beds associated with expansion, enhancement, or modification activities at existing cranberry production operations. The cumulative total acreage of disturbance per cranberry production operation, including but not limited to, filling, flooding, ditching, or clearing, must not exceed 10 acres of waters of the United States, including wetlands. The activity must not result in a net loss of wetland acreage. This NWP does not authorize any discharge of dredged or fill material related to other cranberry production activities such as warehouses, processing facilities, or parking areas. For the purposes of this NWP, the cumulative total of 10 acres will be measured over the period that this NWP is valid.

Notification: The permittee must submit a pre-construction notification to the district engineer once during the period that this NWP is valid, and the NWP will then authorize discharges of dredge or fill material at an existing operation for the permit term, provided the 10-acre limit is not exceeded. (See general condition 32.) (Authority: Section 404)

**35. Maintenance Dredging of Existing Basins.** The removal of accumulated sediment for maintenance of existing marina basins, access channels to marinas or boat slips, and boat slips to previously authorized depths or controlling depths for ingress/egress, whichever is less. All dredged material must be deposited and retained in an area that has no waters of the United States unless otherwise specifically approved by the district engineer under separate authorization. Proper sediment controls must be used for the disposal site. (Authority: Section 10)

**36. Boat Ramps.** Activities required for the construction of boat ramps, provided the activity meets all of the following criteria:

- (a) The discharge into waters of the United States does not exceed 50 cubic yards of concrete, rock, crushed stone or gravel into forms, or in the form of pre-cast concrete planks or slabs, unless the district engineer waives the 50 cubic yard limit by making a written determination concluding that the discharge will result in no more than minimal adverse environmental effects;
- (b) The boat ramp does not exceed 20 feet in width, unless the district engineer waives this criterion by making a written determination concluding that the discharge will result in no more than minimal adverse environmental effects;
- (c) The base material is crushed stone, gravel or other suitable material;
- (d) The excavation is limited to the area necessary for site preparation and all excavated material is removed to an area that has no waters of the United States; and,
- (e) No material is placed in special aquatic sites, including wetlands. The use of unsuitable material that is structurally unstable is not authorized. If dredging in navigable waters of the United States is necessary to provide access to the boat ramp, the dredging must be authorized by another NWP, a regional general permit, or an individual permit.

Notification: The permittee must submit a pre-construction notification to the district engineer prior to commencing the activity if: (1) The discharge into waters of the United States exceeds 50 cubic yards, or (2) the boat ramp exceeds 20 feet in width. (See general condition 32.) (Authorities: Sections 10 and 404)

**37. Emergency Watershed Protection and Rehabilitation.** Work done by or funded by:

- (a) The Natural Resources Conservation Service for a situation requiring immediate action under its emergency Watershed Protection Program (7 CFR part 624);

- (b) The U.S. Forest Service under its Burned-Area Emergency Rehabilitation Handbook (FSH 2509.13);
- (c) The Department of the Interior for wildland fire management burned area emergency stabilization and rehabilitation (DOI Manual part 620, Ch. 3);
- (d) The Office of Surface Mining, or states with approved programs, for abandoned mine land reclamation activities under Title IV of the Surface Mining Control and Reclamation Act (30 CFR subchapter R), where the activity does not involve coal extraction; or
- (e) The Farm Service Agency under its Emergency Conservation Program (7 CFR part 701).

In general, the prospective permittee should wait until the district engineer issues an NWP verification or 45 calendar days have passed before proceeding with the watershed protection and rehabilitation activity. However, in cases where there is an unacceptable hazard to life or a significant loss of property or economic hardship will occur, the emergency watershed protection and rehabilitation activity may proceed immediately and the district engineer will consider the information in the pre-construction notification and any comments received as a result of agency coordination to decide whether the NWP 37 authorization should be modified, suspended, or revoked in accordance with the procedures at 33 CFR 330.5.

Notification: Except in cases where there is an unacceptable hazard to life or a significant loss of property or economic hardship will occur, the permittee must submit a Pre-construction notification to the district engineer prior to commencing the activity (see general condition 32). (Authorities: Sections 10 and 404)

**38. Cleanup of Hazardous and Toxic Waste.** Specific activities required to effect the containment, stabilization, or removal of hazardous or toxic waste materials that are performed, ordered, or sponsored by a government agency with established legal or regulatory authority. Court ordered remedial action plans or related settlements are also authorized by this NWP. This NWP does not authorize the establishment of new disposal sites or the expansion of existing sites used for the disposal of hazardous or toxic waste.

Notification: The permittee must submit a pre-construction notification to the district engineer prior to commencing the activity. (See general condition 32.) (Authorities: Sections 10 and 404)

Note: Activities undertaken entirely on a Comprehensive Environmental Response, Compensation, and Liability Act (CERCLA) site by authority of CERCLA as approved or required by EPA, are not required to obtain permits under Section 404 of the Clean Water Act or Section 10 of the Rivers and Harbors Act.

**39. Commercial and Institutional Developments.** Discharges of dredged or fill material into non-tidal waters of the United States for the construction or expansion of commercial and institutional building foundations and building pads and attendant features that are necessary for the use and maintenance of the structures. Attendant features may include, but are not limited to, roads, parking lots, garages, yards, utility lines, storm water management facilities, wastewater treatment facilities, and recreation facilities such as playgrounds and playing fields. Examples of commercial developments include retail stores, industrial facilities, restaurants, business parks, and shopping centers. Examples of institutional developments include schools, fire stations, government office buildings, judicial buildings, public works buildings, libraries, hospitals, and places of worship. The construction of new golf courses and new ski areas is not authorized by this NWP.

The discharge must not cause the loss of greater than 1/2-acre of non-tidal waters of the United States. The discharge must not cause the loss of more than 300 linear feet of stream bed, unless for intermittent and ephemeral stream beds the district engineer waives the 300 linear foot limit by making a written determination concluding that the discharge will result in no more than minimal adverse environmental effects. The loss of stream bed plus any other losses of jurisdictional wetlands and waters caused by the NWP activity cannot exceed 1/2-acre. This NWP does not authorize discharges into non-tidal wetlands adjacent to tidal waters.

Notification: The permittee must submit a pre-construction notification to the district engineer prior to commencing the activity. (See general condition 32.) (Authorities: Sections 10 and 404)

Note: For any activity that involves the construction of a wind energy generating structure, solar tower, or overhead transmission line, a copy of the PCN and NWP verification will be provided to the Department of Defense Siting Clearinghouse, which will evaluate potential effects on military activities.

**40. Agricultural Activities.** Discharges of dredged or fill material into non-tidal waters of the United States for agricultural activities, including the construction of building pads for farm buildings. Authorized activities include the installation, placement, or construction of drainage tiles, ditches, or levees; mechanized land clearing; land leveling; the relocation of existing serviceable drainage ditches constructed in waters of the United States; and similar activities.

This NWP also authorizes the construction of farm ponds in non-tidal waters of the United States, excluding perennial streams, provided the farm pond is used solely for agricultural purposes. This NWP does not authorize the construction of aquaculture ponds.

This NWP also authorizes discharges of dredged or fill material into non-tidal waters of the United States to relocate existing serviceable drainage ditches constructed in non-tidal streams. The discharge must not cause the loss of greater than 1/2-acre of non-tidal waters of the United States.

The discharge must not cause the loss of more than 300 linear feet of stream bed, unless for intermittent and ephemeral stream beds the district engineer waives the 300 linear foot limit by making a written determination concluding that the discharge will result in no more than minimal adverse environmental effects. The loss of stream bed plus any other losses of jurisdictional wetlands and waters caused by the NWP activity cannot exceed 1/2-acre. This NWP does not authorize discharges into non-tidal wetlands adjacent to tidal waters.

Notification: The permittee must submit a pre-construction notification to the district engineer prior to commencing the activity. (See general condition 32.) (Authorities: Section 404)

Note: Some discharges for agricultural activities may qualify for an exemption under Section 404(f) of the Clean Water Act (see 33 CFR 323.4). This NWP authorizes the construction of farm ponds that do not qualify for the Clean Water Act section 404(f)(1)(C) exemption because of the recapture provision at section 404(f)(2).

**41. Reshaping Existing Drainage Ditches.** Discharges of dredged or fill material into non-tidal waters of the United States, excluding non-tidal wetlands adjacent to tidal waters, to modify the cross-sectional configuration of currently serviceable drainage ditches constructed in waters of the United States, for the purpose of improving water quality by regrading the drainage ditch with gentler slopes, which can reduce erosion, increase growth of vegetation, and increase uptake of nutrients and other substances by vegetation. The reshaping of the ditch cannot increase drainage capacity beyond the original as-built capacity nor can it expand the area drained by the ditch as originally constructed (i.e., the capacity of the ditch must be the same as originally constructed and it cannot drain additional wetlands or other waters of the United States). Compensatory mitigation is not required because the work is designed to improve water quality.

This NWP does not authorize the relocation of drainage ditches constructed in waters of the United States; the location of the centerline of the reshaped drainage ditch must be approximately the same as the location of the centerline of the original drainage ditch. This NWP does not authorize stream channelization or stream relocation projects. (Authority: Section 404)

**42. Recreational Facilities.** Discharges of dredged or fill material into non-tidal waters of the United States for the construction or expansion of recreational facilities. Examples of recreational facilities that may be authorized by this NWP include playing fields (e.g., football fields, baseball fields), basketball courts, tennis courts, hiking trails, bike paths, golf courses, ski areas, horse paths, nature centers, and campgrounds (excluding recreational vehicle parks). This NWP also authorizes the construction or expansion of small support facilities, such as maintenance and storage buildings and stables that are directly related to the recreational activity, but it does not authorize the construction of hotels, restaurants, racetracks, stadiums, arenas, or similar facilities.

The discharge must not cause the loss of greater than 1/2-acre of non-tidal waters of the United States. The discharge must not cause the loss of more than 300 linear feet of stream bed, unless for intermittent and ephemeral stream beds the district engineer waives the 300 linear foot limit by making a written determination concluding that the discharge will result in no more than minimal adverse environmental effects. The loss of stream bed plus any other losses of jurisdictional wetlands and waters caused by the NWP activity cannot exceed 1/2-acre. This NWP does not authorize discharges into non-tidal wetlands adjacent to tidal waters.

Notification: The permittee must submit a pre-construction notification to the district engineer prior to commencing the activity. (See general condition 32.) (Authority: Section 404)

**43. Stormwater Management Facilities.** Discharges of dredged or fill material into non-tidal waters of the United States for the construction of stormwater management facilities, including stormwater detention basins and retention basins and other stormwater management facilities; the construction of water control structures, outfall structures and emergency spillways; the construction of low impact development integrated management features such as bioretention facilities (e.g., rain gardens), vegetated filter strips, grassed swales, and infiltration trenches; and the construction of pollutant reduction green infrastructure features designed to reduce inputs of sediments, nutrients, and other pollutants into waters to meet reduction targets established under Total Daily Maximum Loads set under the Clean Water Act.

This NWP authorizes, to the extent that a section 404 permit is required, discharges of dredged or fill material into non-tidal waters of the United States for the maintenance of stormwater management facilities, low impact development integrated management features, and pollutant reduction green infrastructure features. The maintenance of stormwater management facilities, low impact development integrated management features, and pollutant reduction green infrastructure features that are not waters of the United States does not require a section 404 permit.

The discharge must not cause the loss of greater than 1/2-acre of non-tidal waters of the United States. The discharge must not cause the loss of more than 300 linear feet of stream bed, unless for intermittent and ephemeral stream beds the district engineer waives the 300 linear foot limit by making a written determination concluding that the discharge will result in no more than minimal adverse environmental effects. This NWP does not authorize discharges into non-tidal wetlands adjacent to tidal waters. The loss of stream bed plus any other losses of jurisdictional wetlands and waters caused by the NWP activity cannot exceed 1/2-acre. This NWP does not authorize discharges of dredged or fill material for the construction of new stormwater management facilities in perennial streams.

Notification: For discharges into non-tidal waters of the United States for the construction of new stormwater management facilities or pollutant reduction green infrastructure features, or the expansion of existing stormwater management facilities or pollutant reduction green infrastructure features, the permittee must submit a pre-construction notification to the district engineer prior to commencing the activity. (See general condition 32.) Maintenance activities do not require pre-construction notification if they are limited to restoring the original design capacities of the stormwater management facility or pollutant reduction green infrastructure feature. (Authority: Section 404))

**44. Mining Activities.** Discharges of dredged or fill material into non-tidal waters of the United States for mining activities, except for coal mining activities, provided the activity meets all of the following criteria:

- (a) For mining activities involving discharges of dredged or fill material into non-tidal wetlands, the discharge must not cause the loss of greater than 1/2-acre of non-tidal wetlands;



- (b) For mining activities involving discharges of dredged or fill material in non-tidal open waters (e.g., rivers, streams, lakes, and ponds) the mined area, including permanent and temporary impacts due to discharges of dredged or fill material into jurisdictional waters, must not exceed 1/2-acre; and
- (c) The acreage loss under paragraph (a) plus the acreage impact under paragraph (b) does not exceed 1/2-acre.

The discharge must not cause the loss of more than 300 linear feet of stream bed, unless for intermittent and ephemeral stream beds the district engineer waives the 300 linear foot limit by making a written determination concluding that the discharge will result in no more than minimal adverse environmental effects.

The loss of stream bed plus any other losses of jurisdictional wetlands and waters caused by the NWP activity cannot exceed 1/2-acre.

This NWP does not authorize discharges into non-tidal wetlands adjacent to tidal waters.

Notification: The permittee must submit a pre-construction-notification to the district engineer prior to commencing the activity. (See general condition 32.) If reclamation is required by other statutes, then a copy of the final reclamation plan must be submitted with the pre-construction notification. (Authorities: Sections 10 and 404)

**45. Repair of Uplands Damaged by Discrete Events.** This NWP authorizes discharges of dredged or fill material, including dredging or excavation, into all waters of the United States for activities associated with the restoration of upland areas damaged by storms, floods, or other discrete events. This NWP authorizes bank stabilization to protect the restored uplands. The restoration of the damaged areas, including any bank stabilization, must not exceed the contours, or ordinary high water mark, that existed before the damage occurred. The district engineer retains the right to determine the extent of the pre-existing conditions and the extent of any restoration work authorized by this NWP. The work must commence, or be under contract to commence, within two years of the date of damage, unless this condition is waived in writing by the district engineer. This NWP cannot be used to reclaim lands lost to normal erosion processes over an extended period.

This NWP does not authorize beach restoration or nourishment.

Minor dredging is limited to the amount necessary to restore the damaged upland area and should not significantly alter the pre-existing bottom contours of the waterbody.

Notification: The permittee must submit a pre-construction notification to the district engineer (see general condition 32) within 12 months of the date of the damage; for major storms, floods, or other discrete events, the district engineer may waive the 12-month limit for submitting a pre-construction notification if the permittee can demonstrate funding, contract, or other similar delays. The pre-construction notification must include documentation, such as a recent topographic survey or photographs, to justify the extent of the proposed restoration. (Authority: Sections 10 and 404)

Note: The uplands themselves that are lost as a result of a storm, flood, or other discrete event can be replaced without a section 404 permit, if the uplands are restored to the ordinary high water mark (in non-tidal waters) or high tide line (in tidal waters). (See also 33 CFR 328.5.) This NWP authorizes discharges of dredged or fill material into waters of the United States associated with the restoration of uplands

**46. Discharges in Ditches.** Discharges of dredged or fill material into non-tidal ditches that are: (1) Constructed in uplands, (2) receive water from an area determined to be a water of the United States prior to the construction of the ditch, (3) divert water to an area determined to be a water of the United States prior to the construction of the ditch, and (4) determined to be waters of the United States. The discharge must not cause the loss of greater than one acre of waters of the United States.

This NWP does not authorize discharges of dredged or fill material into ditches constructed in streams or other waters of the United States, or in streams that have been relocated in uplands. This NWP does not authorize discharges of dredged or fill material that increase the capacity of the ditch and drain those areas determined to be waters of the United States prior to construction of the ditch.

Notification: The permittee must submit a pre-construction notification to the district engineer prior to commencing the activity. (See general condition 32.) (Authority: Section 404)

#### **47. [Reserved]**

**48. Commercial Shellfish Aquaculture Activities.** Discharges of dredged or fill material into waters of the United States or structures or work in navigable waters of the United States necessary for new and continuing commercial shellfish aquaculture operations in authorized project areas. For the purposes of this NWP, the project area is the area in which the operator is authorized to conduct commercial shellfish aquaculture activities, as identified through a lease or permit issued by an appropriate state or local government agency, a treaty, or any easement, lease, deed, contract, or other legally binding agreement that establishes an enforceable property interest for the operator. A "new commercial shellfish aquaculture operation" is an operation in a project area where commercial shellfish aquaculture activities have not been conducted during the past 100 years.

This NWP authorizes the installation of buoys, floats, racks, trays, nets, lines, tubes, containers, and other structures into navigable waters of the United States. This NWP also authorizes discharges of dredged or fill material into waters of the United States necessary for shellfish seeding, rearing, cultivating, transplanting, and harvesting activities. Rafts and other floating structures must be securely anchored and clearly marked.

This NWP does not authorize:

- (a) The cultivation of a nonindigenous species unless that species has been previously cultivated in the waterbody;
- (b) The cultivation of an aquatic nuisance species as defined in the Nonindigenous Aquatic Nuisance Prevention and Control Act of 1990;

- (c) Attendant features such as docks, piers, boat ramps, stockpiles, or staging areas, or the deposition of shell material back into waters of the United States as waste; or
- (d) Activities that directly affect more than 1/2-acre of submerged aquatic vegetation beds in project areas that have not been used for commercial shellfish aquaculture activities during the past 100 years.

Notification: The permittee must submit a pre-construction notification to the district engineer if: (1) The activity will include a species that has never been cultivated in the waterbody; or (2) the activity occurs in a project area that has not been used for commercial shellfish aquaculture activities during the past 100 years. If the operator will be conducting commercial shellfish aquaculture activities in multiple contiguous project areas, he or she can either submit one PCN for those contiguous project areas or submit a separate PCN for each project area. (See general condition 32.)

In addition to the information required by paragraph (b) of general condition 32, the pre-construction notification must also include the following information: (1) A map showing the boundaries of the project area(s), with latitude and longitude coordinates for each corner of each project area; (2) the name(s) of the species that will be cultivated during the period this NWP is in effect; (3) whether canopy predator nets will be used; (4) whether suspended cultivation techniques will be used; and (5) general water depths in the project area(s) (a detailed survey is not required). No more than one pre-construction notification per project area or group of contiguous project areas should be submitted for the commercial shellfish operation during the effective period of this NWP. The pre-construction notification should describe all species and culture activities the operator expects to undertake in the project area or group of contiguous project areas during the effective period of this NWP. If an operator intends to undertake unanticipated changes to the commercial shellfish aquaculture operation during the effective period of this NWP, and those changes require Department of the Army authorization, the operator must contact the district engineer to request a modification of the NWP verification; a new pre-construction notification does not need to be submitted (Authorities: Sections 10 and 404)

Note 1: The permittee should notify the applicable U.S. Coast Guard office regarding the project.

Note 2: To prevent introduction of aquatic nuisance species, no material that has been taken from a different waterbody may be reused in the current project area, unless it has been treated in accordance with the applicable regional aquatic nuisance species management plan.

Note 3: The Nonindigenous Aquatic Nuisance Prevention and Control Act of 1990 defines "aquatic nuisance species" as "a nonindigenous species that threatens the diversity or abundance of native species or the ecological stability of infested waters, or commercial, agricultural, aquacultural, or recreational activities dependent on such waters."

**49. Coal Remining Activities.** Activities. Discharges of dredged or fill material into non-tidal waters of the United States associated with the remining and reclamation of lands that were previously mined for coal. The activities must already be authorized, or they must currently be in process as part of an integrated permit processing procedure, by the Department of the Interior Office of Surface Mining Reclamation and Enforcement, or by states with approved programs under Title IV or Title V of the Surface Mining Control and Reclamation Act of 1977 (SMCRA). Areas previously mined include reclaimed mine sites, abandoned mine land areas, or lands under bond forfeiture contracts.

As part of the project, the permittee may conduct new coal mining activities in conjunction with the remining activities when he or she clearly demonstrates to the district engineer that the overall mining plan will result in a net increase in aquatic resource functions. The Corps will consider the SMCRA agency's decision regarding the amount of currently undisturbed adjacent lands needed to facilitate the remining and reclamation of the previously mined area. The total area disturbed by new mining must not exceed 40 percent of the total acreage covered by both the remined area and the additional area necessary to carry out the reclamation of the previously mined area.

The permittee must submit a pre-construction notification and a document describing how the overall mining plan will result in a net increase in aquatic resource functions to the district engineer and receive written authorization prior to commencing the activity. (See general condition 32.) (Authorities: Sections 10 and 404)

**50. Underground Coal Mining Activities.** Discharges of dredged or fill material into non-tidal waters of the United States associated with underground coal mining and reclamation operations provided the activities are authorized, or are currently being processed as part of an integrated permit processing procedure, by the Department of the Interior, Office of Surface Mining Reclamation and Enforcement, or by states with approved programs under Title V of the Surface Mining Control and Reclamation Act of 1977.

The discharge must not cause the loss of greater than 1/2-acre of non-tidal waters of the United States. The discharge must not cause the loss of more than 300 linear feet of stream bed, unless for intermittent and ephemeral stream beds the district engineer waives the 300 linear foot limit by making a written determination concluding that the discharge will result in no more than minimal adverse environmental effects. The loss of stream bed plus any other losses of jurisdictional wetlands and waters caused by the NWP activity cannot exceed 1/2-acre. This NWP does not authorize discharges into non-tidal wetlands adjacent to tidal waters. This NWP does not authorize coal preparation and processing activities outside of the mine site.

Notification: The permittee must submit a pre-construction notification to the district engineer and receive written authorization prior to commencing the activity. (See general condition 32.) If reclamation is required by other statutes, then a copy of the reclamation plan must be submitted with the pre-construction notification. (Authorities: Sections 10 and 404)

Note: Coal preparation and processing activities outside of the mine site may be authorized by NWP 21.

**51. Land-Based Renewable Energy Generation Facilities.** Discharges of dredged or fill material into non-tidal waters of the United States for the construction, expansion, or modification of

land-based renewable energy production facilities, including attendant features. Such facilities include infrastructure to collect solar (concentrating solar power and photovoltaic), wind, biomass, or geothermal energy. Attendant features may include, but are not limited to roads, parking lots, and stormwater management facilities within the land-based renewable energy generation facility.

The discharge must not cause the loss of greater than 1/2-acre of non-tidal waters of the United States. The discharge must not cause the loss of more than 300 linear feet of stream bed, unless for intermittent and ephemeral stream beds the district engineer waives the 300 linear foot limit by making a written determination concluding that the discharge will result in no more than minimal adverse environmental effects. The loss of stream bed plus any other losses of jurisdictional wetlands and waters caused by the NWP activity cannot exceed 1/2-acre. This NWP does not authorize discharges into non-tidal wetlands adjacent to tidal waters.

Notification: The permittee must submit a pre-construction notification to the district engineer prior to commencing the activity if the discharge results in the loss of greater than 1/10-acre of waters of the United States. (See general condition 32.) (Authorities: Sections 10 and 404)

Note 1: Utility lines constructed to transfer the energy from the land-based renewable energy generation facility to a distribution system, regional grid, or other facility are generally considered to be linear projects and each separate and distant crossing of a waterbody is eligible for treatment as a separate single and complete linear project. Those utility lines may be authorized by NWP 12 or another Department of the Army authorization.

Note 2: If the only activities associated with the construction, expansion, or modification of a land-based renewable energy generation facility that require Department of the Army authorization are discharges of dredged or fill material into waters of the United States to construct, maintain, repair, and/or remove utility lines and/or road crossings, then NWP 12 and/or NWP 14 shall be used if those activities meet the terms and conditions of NWPs 12 and 14, including any applicable regional conditions and any case-specific conditions imposed by the district engineer.

Note 3: For any activity that involves the construction of a wind energy generating structure, solar tower, or overhead transmission line, a copy of the PCN and NWP verification will be provided to the Department of Defense Siting Clearinghouse, which will evaluate potential effects on military activities.

**52. Water-Based Renewable Energy Generation Pilot Projects.** Structures and work in navigable waters of the United States and discharges of dredged or fill material into waters of the United States for the construction, expansion, modification, or removal of water-based wind, water-based solar, wave energy, or hydrokinetic renewable energy generation pilot projects and their attendant features. Attendant features may include, but are not limited to, land-based collection and distribution facilities, control facilities, roads, parking lots, and stormwater management facilities.

For the purposes of this NWP, the term "pilot project" means an experimental project where the water-based renewable energy generation units will be monitored to collect information on their performance and environmental effects at the project site.

The discharge must not cause the loss of greater than 1/2-acre of waters of the United States, including the loss of more than 300 linear feet of stream bed, unless for intermittent and ephemeral stream beds the district engineer waives the 300 linear foot limit by making a written determination concluding that the discharge will result in no more than minimal adverse environmental effects. The loss of stream bed plus any other losses of jurisdictional wetlands and waters caused by the NWP activity cannot exceed 1/2-acre.

The placement of a transmission line on the bed of a navigable water of the United States from the renewable energy generation unit(s) to a land-based collection and distribution facility is considered a structure under Section 10 of the Rivers and Harbors Act of 1899 (see 33 CFR 322.2(b)), and the placement of the transmission line on the bed of a navigable water of the United States is not a loss of waters of the United States for the purposes of applying the 1/2-acre or 300 linear foot limits.

For each single and complete project, no more than 10 generation units (e.g., wind turbines, wave energy devices, or hydrokinetic devices) are authorized. For floating solar panels in navigable waters of the United States, each single and complete project cannot exceed 1/2-acre in water surface area covered by the floating solar panels.

This NWP does not authorize activities in coral reefs. Structures in an anchorage area established by the U.S. Coast Guard must comply with the requirements in 33 CFR 322.5(1)(2). Structures may not be placed in established danger zones or restricted areas designated in 33 CFR part 334, Federal navigation channels, shipping safety fairways or traffic separation schemes established by the U.S. Coast Guard (see 33 CFR 322.5(1)(1)), or EPA or Corps designated open water dredged material disposal areas.

Upon completion of the pilot project, the generation units, transmission lines, and other structures or fills associated with the pilot project must be removed to the maximum extent practicable unless they are authorized by a separate Department of the Army authorization, such as another NWP, an individual permit, or a regional general permit. Completion of the pilot project will be identified as the date of expiration of the Federal Energy Regulatory Commission (FERC) license, or the expiration date of the NWP authorization if no FERC license is required.

Notification: The permittee must submit a pre-construction notification to the district engineer prior to commencing the activity. (See general condition 32.) (Authorities: Sections 10 and 404)

Note 1: Utility lines constructed to transfer the energy from the land-based collection facility to a distribution system, regional grid, or other facility are generally considered to be linear projects and each separate and distant crossing of a waterbody is eligible for treatment as a separate single and complete linear project. Those utility lines may be authorized by NWP 12 or another Department of the Army authorization.

Note 2: An activity that is located on an existing locally or federally maintained U.S. Army Corps of Engineers project requires separate approval from the Chief of Engineers or District Engineer under 33 U.S.C. 408.

Note 3: If the pilot project generation units, including any transmission lines, are placed in navigable waters of the United States (i.e., section 10 waters) within the coastal United States, the Great Lakes, and United States territories, copies of the NWP verification will be sent by the Corps to the National Oceanic and Atmospheric Administration, National Ocean Service, for charting the generation units and associated transmission line(s) to protect navigation.

Note 4: Hydrokinetic renewable energy generation projects that require authorization by the Federal Energy Regulatory Commission under the Federal Power Act of 1920 do not require separate authorization from the Corps under section 10 of the Rivers and Harbors Act of 1899.

Note 5: For any activity that involves the construction of a wind energy generating structure, solar tower, or overhead transmission line, a copy of the PCN and NWP verification will be provided to the Department of Defense Siting Clearinghouse, which will evaluate potential effects on military activities.

**53. Removal of Low-Head Dams.** Structures and work in navigable waters of the United States and discharges of dredged or fill material into waters of the United States associated with the removal of low-head dams.

For the purposes of this NWP, the term "low-head dam" is defined as a dam built across a stream to pass flows from upstream over all, or nearly all, of the width of the dam crest on a continual and uncontrolled basis. (During a drought, there might not be water flowing over the dam crest.) In general, a low-head dam does not have a separate spillway or spillway gates but it may have an uncontrolled spillway. The dam crest is the top of the dam from left abutment to right abutment, and if present, an uncontrolled spillway. A low-head dam provides little storage function.

The removed low-head dam structure must be deposited and retained in an area that has no waters of the United States unless otherwise specifically approved by the district engineer under separate authorization.

Because the removal of the low-head dam will result in a net increase in ecological functions and services provided by the stream, as a general rule compensatory mitigation is not required for activities authorized by this NWP. However, the district engineer may determine for a particular low-head dam removal activity that compensatory mitigation is necessary to ensure the authorized activity results in no more than minimal adverse environmental effects.

Notification: The permittee must submit a pre-construction notification to the district engineer prior to commencing the activity. (See general condition 32.)  
(Authorities: Sections 10 and 404)

Note: This NWP does not authorize discharges of dredged or fill material into waters of the United States or structures or work in navigable waters to restore the stream in the vicinity of the low-head dam, including the former impoundment area. Nationwide permit 27 or other Department of the Army permits may authorize such activities. This NWP does not authorize discharges of dredged or fill material into waters of the United States or structures or work in navigable waters to stabilize stream banks. Bank stabilization activities may be authorized by NWP 13 or other Department of the Army permits.

**54. Living Shorelines.** Structures and work in navigable waters of the United States and discharges of dredged or fill material into waters of the United States for the construction and maintenance of living shorelines to stabilize banks and shores in coastal waters, which includes the Great Lakes, along shores with small fetch and gentle slopes that are subject to low- to mid-energy waves. A living shoreline has a footprint that is made up mostly of native material. It incorporates vegetation or other living, natural "soft" elements alone or in combination with some type of harder shoreline structure (e.g., oyster or mussel reefs or rock sills) for added protection and stability. Living shorelines should maintain the natural continuity of the land-water interface, and retain or enhance shoreline ecological processes. Living shorelines must have a substantial biological component, either tidal or lacustrine fringe wetlands or oyster or mussel reef structures. The following conditions must be met:

- (a) The structures and fill area, including sand fills, sills, breakwaters, or reefs, cannot extend into the waterbody more than 30 feet from the mean low water line in tidal waters or the ordinary high water mark in the Great Lakes, unless the district engineer waives this criterion by making a written determination concluding that the activity will result in no more than minimal adverse environmental effects;
- (b) The activity is no more than 500 feet in length along the bank, unless the district engineer waives this criterion by making a written determination concluding that the activity will result in no more than minimal adverse environmental effects;
- (c) Coir logs, coir mats, stone, native oyster shell, native wood debris, and other structural materials must be adequately anchored, of sufficient weight, or installed in a manner that prevents relocation in most wave action or water flow conditions, except for extremely severe storms;
- (d) For living shorelines consisting of tidal or lacustrine fringe wetlands, native plants appropriate for current site conditions, including salinity, must be used if the site is planted by the permittee;
- (e) Discharges of dredged or fill material into waters of the United States, and oyster or mussel reef structures in navigable waters, must be the minimum necessary for the establishment and maintenance of the living shoreline;
- (f) If sills, breakwaters, or other structures must be constructed to protect fringe wetlands for the living shoreline, those structures must be the minimum size necessary to protect those fringe wetlands;
- (g) The activity must be designed, constructed, and maintained so that it has no more than minimal adverse effects on water movement between the waterbody and the shore and the movement of aquatic organisms between the waterbody and the shore; and
- (h) The living shoreline must be properly maintained, which may require periodic repair of sills, breakwaters, or reefs, or replacing sand fills after severe

storms or erosion events. Vegetation may be replanted to maintain the living shoreline. This NWP authorizes those maintenance and repair activities, including any minor deviations necessary to address changing environmental conditions.

This NWP does not authorize beach nourishment or land reclamation activities.

Notification: The permittee must submit a pre-construction notification to the district engineer prior to commencing the construction of the living shoreline. (See general condition 32.) The pre-construction notification must include a delineation of special aquatic sites (see paragraph (b)(4) of general condition 32). Pre-construction notification is not required for maintenance and repair activities for living shorelines unless required by applicable NWP general conditions or regional conditions. (Authorities: Sections 10 and 404)

Note: In waters outside of coastal waters, nature-based bank stabilization techniques, such as bioengineering and vegetative stabilization, may be authorized by NWP 13.

### C. Nationwide Permit General Conditions

To qualify for NWP authorization, the prospective permittee must comply with the following general conditions, as applicable, in addition to any regional or case-specific conditions imposed by the division engineer or district engineer. Prospective permittees should contact the appropriate Corps district office to determine if regional conditions have been imposed on an NWP. Prospective permittees should also contact the appropriate Corps district office to determine the status of Clean Water Act Section 401 water quality certification and/or Coastal Zone Management Act consistency for an NWP. Every person who may wish to obtain permit authorization under one or more NWPs, or who is currently relying on an existing or prior permit authorization under one or more NWPs, has been and is on notice that all of the provisions of 33 CFR 330.1 through 330.6 apply to every NWP authorization. Note especially 33 CFR 330.5 relating to the modification, suspension, or revocation of any NWP authorization.

1. Navigation. (a) No activity may cause more than a minimal adverse effect on navigation. (b) Any safety lights and signals prescribed by the U.S. Coast Guard, through regulations or otherwise, must be installed and maintained at the permittee's expense on authorized facilities in navigable waters of the United States. (c) The permittee understands and agrees that, if future operations by the United States require the removal, relocation, or other alteration, of the structure or work herein authorized, or if, in the opinion of the Secretary of the Army or his authorized representative, said structure or work shall cause unreasonable obstruction to the free navigation of the navigable waters, the permittee will be required, upon due notice from the Corps of Engineers, to remove, relocate, or alter the structural work or obstructions caused thereby, without expense to the United States. No claim shall be made against the United States on account of any such removal or alteration.
2. Aquatic Life Movements. No activity may substantially disrupt the necessary life cycle movements of those species of aquatic life indigenous to the waterbody, including those species that normally migrate through the area, unless the activity's primary purpose is to impound water. All permanent and temporary crossings of waterbodies shall be suitably culverted, bridged, or otherwise designed and constructed to maintain low flows to sustain the movement of those aquatic species. If a bottomless culvert cannot be used, then the crossing should be designed and constructed to minimize adverse effects to aquatic life movements.
3. Spawning Areas. Activities in spawning areas during spawning seasons must be avoided to the maximum extent practicable. Activities that result in the physical destruction (e.g., through excavation, fill, or downstream smothering by substantial turbidity) of an important spawning area are not authorized.
4. Migratory Bird Breeding Areas. Activities in waters of the United States that serve as breeding areas for migratory birds must be avoided to the maximum extent practicable.
5. Shellfish Beds. No activity may occur in areas of concentrated shellfish populations, unless the activity is directly related to a shellfish harvesting activity authorized by NWPs 4 and 48, or is a shellfish seeding or habitat restoration activity authorized by NWP 27.
6. Suitable Material. No activity may use unsuitable material (e.g., trash, debris, car bodies, asphalt, etc.). Material used for construction or discharged must be free from toxic pollutants in toxic amounts (see section 307 of the Clean Water Act).
7. Water Supply Intakes. No activity may occur in the proximity of a public water supply intake, except where the activity is for the repair or improvement of public water supply intake structures or adjacent bank stabilization.
8. Adverse Effects from Impoundments. If the activity creates an impoundment of water, adverse effects to the aquatic system due to accelerating the passage of water, and/or restricting its flow must be minimized to the maximum extent practicable.
9. Management of Water Flows. To the maximum extent practicable, the pre-construction course, condition, capacity, and location of open waters must be maintained for each activity, including stream channelization, storm water management activities, and temporary and permanent road crossings, except as provided below. The activity must be constructed to withstand expected high flows. The activity must not restrict or impede the passage of normal or high flows, unless the primary purpose of the activity is to impound water or manage high flows. The activity may alter the pre-construction course, condition, capacity, and location of open waters if it benefits the aquatic environment (e.g., stream restoration or relocation activities).
10. Fills Within 100-Year Floodplains. The activity must comply with applicable FEMA-approved state or local floodplain management requirements.
11. Equipment. Heavy equipment working in wetlands or mudflats must be placed on mats, or other measures must be taken to minimize soil disturbance.
12. Soil Erosion and Sediment Controls. Appropriate soil erosion and sediment controls must be used and maintained in effective operating condition during construction, and all exposed soil and other fills, as well as any work below the ordinary high water mark or high tide line, must be permanently stabilized at the earliest practicable date. Permittees are



- encouraged to perform work within waters of the United States during periods of low-flow or no-flow, or during low tides.
13. Removal of Temporary Fills. Temporary fills must be removed in their entirety and the affected areas returned to pre-construction elevations. The affected areas must be revegetated, as appropriate.
  14. Proper Maintenance. Any authorized structure or fill shall be properly maintained, including maintenance to ensure public safety and compliance with applicable NWP general conditions, as well as any activity-specific conditions added by the district engineer to an NWP authorization.
  15. Single and Complete Project. The activity must be a single and complete project. The same NWP cannot be used more than once for the same single and complete project.
  16. Wild and Scenic Rivers. (a) No NWP activity may occur in a component of the National Wild and Scenic River System, or in a river officially designated by Congress as a "study river" for possible inclusion in the system while the river is in an official study status, unless the appropriate Federal agency with direct management responsibility for such river, has determined in writing that the proposed activity will not adversely affect the Wild and Scenic River designation or study status.  
(b) If a proposed NWP activity will occur in a component of the National Wild and Scenic River System, or in a river officially designated by Congress as a "study river" for possible inclusion in the system while the river is in an official study status, the permittee must submit a pre-construction notification (see general condition 32). The district engineer will coordinate the PCN with the Federal agency with direct management responsibility for that river. The permittee shall not begin the NWP activity until notified by the district engineer that the Federal agency with direct management responsibility for that river has determined in writing that the proposed NWP activity will not adversely affect the Wild and Scenic River designation or study status.  
(c) Information on Wild and Scenic Rivers may be obtained from the appropriate Federal land management agency responsible for the designated Wild and Scenic River or study river (e.g., National Park Service, U.S. Forest Service, Bureau of Land Management, U.S. Fish and Wildlife Service). Information on these rivers is also available at:  
<http://www.rivers.gov/>.
  17. Tribal Rights. No NWP activity may cause more than minimal adverse effects on tribal rights (including treaty rights), protected tribal resources, or tribal lands.
  18. Endangered Species. (a) No activity is authorized under any NWP which is likely to directly or indirectly jeopardize the continued existence of a threatened or endangered species or a species proposed for such designation, as identified under the Federal Endangered Species Act (ESA), or which will directly or indirectly destroy or adversely modify the critical habitat of such species. No activity is authorized under any NWP which "may affect" a listed species or critical habitat, unless ESA section 7 consultation addressing the effects of the proposed activity has been completed. Direct effects are the immediate effects on listed species and critical habitat caused by the NWP activity. Indirect effects are those effects on listed species and critical habitat that are caused by the NWP activity and are later in time, but still are reasonably certain to occur.  
(b) Federal agencies should follow their own procedures for complying with the requirements of the ESA. If pre-construction notification is required for the proposed activity, the Federal permittee must provide the district engineer with the appropriate documentation to demonstrate compliance with those requirements. The district engineer will verify that the appropriate documentation has been submitted. If the appropriate documentation has not been submitted, additional ESA section 7 consultation may be necessary for the activity and the respective federal agency would be responsible for fulfilling its obligation under section 7 of the ESA.  
(c) Non-federal permittees must submit a pre-construction notification to the district engineer if any listed species or designated critical habitat might be affected or is in the vicinity of the activity, or if the activity is located in designated critical habitat, and shall not begin work on the activity until notified by the district engineer that the requirements of the ESA have been satisfied and that the activity is authorized. For activities that might affect Federally-listed endangered or threatened species or designated critical habitat, the pre-construction notification must include the name(s) of the endangered or threatened species that might be affected by the proposed activity or that utilize the designated critical habitat that might be affected by the proposed activity. The district engineer will determine whether the proposed activity "may affect" or will have "no effect" to listed species and designated critical habitat and will notify the non-Federal applicant of the Corps' determination within 45 days of receipt of a complete pre-construction notification. In cases where the non-Federal applicant has identified listed species or critical habitat that might be affected or is in the vicinity of the activity, and has so notified the Corps, the applicant shall not begin work until the Corps has provided notification that the proposed activity will have "no effect" on listed species or critical habitat, or until ESA section 7 consultation has been completed. If the non-Federal applicant has not heard back from the Corps within 45 days, the applicant must still wait for notification from the Corps.  
(d) As a result of formal or informal consultation with the FWS or NMFS the district engineer may add species-specific permit conditions to the NWPs.  
(e) Authorization of an activity by an NWP does not authorize the "take" of a threatened or endangered species as defined under the ESA. In the absence of separate authorization (e.g., an ESA Section 10 Permit, a Biological Opinion with "incidental take" provisions, etc.) from the FWS or the NMFS, the Endangered Species Act prohibits any person subject to the jurisdiction of the United States to take a listed species, where "take" means to harass, harm, pursue, hunt, shoot, wound, kill, trap, capture, or collect, or to attempt to engage in any such conduct. The word "harm" in the definition of "take" means an act which actually kills or injures wildlife. Such an act may include significant habitat modification or degradation where it actually kills

- or injures wildlife by significantly impairing essential behavioral patterns, including breeding, feeding or sheltering.
- (f) If the non-federal permittee has a valid ESA section 10(a)(1)(B) incidental take permit with an approved Habitat Conservation Plan for a project or a group of projects that includes the proposed NWP activity, the non-federal applicant should provide a copy of that ESA section 10(a)(1)(B) permit with the PCN required by paragraph (c) of this general condition. The district engineer will coordinate with the agency that issued the ESA section 10(a)(1)(B) permit to determine whether the proposed NWP activity and the associated incidental take were considered in the internal ESA section 7 consultation conducted for the ESA section 10(a)(1)(B) permit. If that coordination results in concurrence from the agency that the proposed NWP activity and the associated incidental take were considered in the internal ESA section 7 consultation for the ESA section 10(a)(1)(B) permit, the district engineer does not need to conduct a separate ESA section 7 consultation for the proposed NWP activity. The district engineer will notify the non-federal applicant within 45 days of receipt of a complete pre-construction notification whether the ESA section 10(a)(1)(B) permit covers the proposed NWP activity or whether additional ESA section 7 consultation is required.
- (g) Information on the location of threatened and endangered species and their critical habitat can be obtained directly from the offices of the FWS and NMFS or their world wide Web pages at <http://www.fws.gov/> or <http://www.fws.gov/ipac> and <http://www.nmfs.noaa.gov/pr/species/esa/> respectively.
19. Migratory Birds and Bald and Golden Eagles. The permittee is responsible for ensuring their action complies with the Migratory Bird Treaty Act and the Bald and Golden Eagle Protection Act. The permittee is responsible for contacting appropriate local office of the U.S. Fish and Wildlife Service to determine applicable measures to reduce impacts to migratory birds or eagles, including whether "incidental take" permits are necessary and available under the Migratory Bird Treaty Act or Bald and Golden Eagle Protection Act for a particular activity.
20. Historic Properties. (a) In cases where the district engineer determines that the activity may have the potential to cause effects to properties listed, or eligible for listing, in the National Register of Historic Places, the activity is not authorized, until the requirements of Section 106 of the National Historic Preservation Act (NHPA) have been satisfied.
- (b) Federal permittees should follow their own procedures for complying with the requirements of section 106 of the National Historic Preservation Act. If pre-construction notification is required for the proposed NWP activity, the Federal permittee must provide the district engineer with the appropriate documentation to demonstrate compliance with those requirements. The district engineer will verify that the appropriate documentation has been submitted. If the appropriate documentation is not submitted, then additional consultation under section 106 may be necessary. The respective federal agency is responsible for fulfilling its obligation to comply with section 106.
- (c) Non-federal permittees must submit a pre-construction notification to the district engineer if the NWP activity might have the potential to cause effects to any historic properties listed on, determined to be eligible for listing on, or potentially eligible for listing on the National Register of Historic Places, including previously unidentified properties. For such activities, the pre-construction notification must state which historic properties might have the potential to be affected by the proposed NWP activity or include a vicinity map indicating the location of the historic properties or the potential for the presence of historic properties. Assistance regarding information on the location of, or potential for, the presence of historic properties can be sought from the State Historic Preservation Officer, Tribal Historic Preservation Officer, or designated tribal representative, as appropriate, and the National Register of Historic Places (see 33 CFR 330.4(g)). When reviewing pre-construction notifications, district engineers will comply with the current procedures for addressing the requirements of section 106 of the National Historic Preservation Act. The district engineer shall make a reasonable and good faith effort to carry out appropriate identification efforts, which may include background research, consultation, oral history interviews, sample field investigation, and field survey. Based on the information submitted in the PCN and these identification efforts, the district engineer shall determine whether the proposed NWP activity has the potential to cause effects on the historic properties. Section 106 consultation is not required when the district engineer determines that the activity does not have the potential to cause effects on historic properties (see 36 CFR 800.3(a)). Section 106 consultation is required when the district engineer determines that the activity has the potential to cause effects on historic properties. The district engineer will conduct consultation with consulting parties identified under 36 CFR 800.2(c) when he or she makes any of the following effect determinations for the purposes of section 106 of the NHPA: no historic properties affected, no adverse effect, or adverse effect. Where the non-Federal applicant has identified historic properties on which the activity might have the potential to cause effects and so notified the Corps, the non-Federal applicant shall not begin the activity until notified by the district engineer either that the activity has no potential to cause effects to historic properties or that NHPA section 106 consultation has been completed.
- (d) For non-federal permittees, the district engineer will notify the prospective permittee within 45 days of receipt of a complete pre-construction notification whether NHPA section 106 consultation is required. If NHPA section 106 consultation is required, the district engineer will notify the non-Federal applicant that he or she cannot begin the activity until section 106 consultation is completed. If the non-Federal applicant has not heard back from the Corps within 45 days, the applicant must still wait for notification from the Corps.
- (e) Prospective permittees should be aware that section 110k of the NHPA (54 U.S.C. 306113) prevents the Corps from granting a permit or other assistance to an applicant who, with

intent to avoid the requirements of section 106 of the NHPA, has intentionally significantly adversely affected a historic property to which the permit would relate, or having legal power to prevent it, allowed such significant adverse effect to occur, unless the Corps, after consultation with the Advisory Council on Historic Preservation (ACHP), determines that circumstances justify granting such assistance despite the adverse effect created or permitted by the applicant. If circumstances justify granting the assistance, the Corps is required to notify the ACHP and provide documentation specifying the circumstances, the degree of damage to the integrity of any historic properties affected, and proposed mitigation. This documentation must include any views obtained from the applicant, SHPO/THPO, appropriate Indian tribes if the undertaking occurs on or affects historic properties on tribal lands or affects properties of interest to those tribes, and other parties known to have a legitimate interest in the impacts to the permitted activity on historic properties.

21. Discovery of Previously Unknown Remains and Artifacts. If you discover any previously unknown historic, cultural or archeological remains and artifacts while accomplishing the activity authorized by this permit, you must immediately notify the district engineer of what you have found, and to the maximum extent practicable, avoid construction activities that may affect the remains and artifacts until the required coordination has been completed. The district engineer will initiate the Federal, Tribal, and state coordination required to determine if the items or remains warrant a recovery effort or if the site is eligible for listing in the National Register of Historic Places.
22. Designated Critical Resource Waters. Critical resource waters include, NOAA-managed marine sanctuaries and marine monuments, and National Estuarine Research Reserves. The district engineer may designate, after notice and opportunity for public comment, additional waters officially designated by a state as having particular environmental or ecological significance, such as outstanding national resource waters or state natural heritage sites. The district engineer may also designate additional critical resource waters after notice and opportunity for public comment.
  - (a) Discharges of dredged or fill material into waters of the United States are not authorized by NWPs 7, 12, 14, 16, 17, 21, 29, 31, 35, 39, 40, 42, 43, 44, 49, 50, 51, and 52 for any activity within, or directly affecting, critical resource waters, including wetlands adjacent to such waters.
  - (b) For NWPs 3, 8, 10, 13, 15, 18, 19, 22, 23, 25, 27, 28, 30, 33, 34, 36, 37, 38, and 54, notification is required in accordance with general condition 32, for any activity proposed in the designated critical resource waters including wetlands adjacent to those waters. The district engineer may authorize activities under these NWPs only after it is determined that the impacts to the critical resource waters will be no more than minimal.
23. Mitigation. The district engineer will consider the following factors when determining appropriate and practicable mitigation necessary to ensure that the individual and cumulative adverse environmental effects are no more than minimal:
  - (a) The activity must be designed and constructed to avoid and minimize adverse effects, both temporary and permanent, to waters of the United States to the maximum extent practicable at the project site (i.e., on site).
  - (b) Mitigation in all its forms (avoiding, minimizing, rectifying, reducing, or compensating for resource losses) will be required to the extent necessary to ensure that the individual and cumulative adverse environmental effects are no more than minimal.
  - (c) Compensatory mitigation at a minimum one-for-one ratio will be required for all wetland losses that exceed 1/10-acre and require pre-construction notification, unless the district engineer determines in writing that either some other form of mitigation would be more environmentally appropriate or the adverse environmental effects of the proposed activity are no more than minimal, and provides an activity-specific waiver of this requirement. For wetland losses of 1/10-acre or less that require Pre-construction notification, the district engineer may determine on a case-by-case basis that compensatory mitigation is required to ensure that the activity results in only minimal adverse environmental effects.
  - (d) For losses of streams or other open waters that require pre-construction notification, the district engineer may require compensatory mitigation to ensure that the activity results in no more than minimal adverse environmental effects. Compensatory mitigation for losses of streams should be provided, if practicable, through stream rehabilitation, enhancement, or preservation, since streams are difficult-to-replace resources (see 33 CFR 332.3(e)(3)).
  - (e) Compensatory mitigation plans for NWP activities in or near streams or other open waters will normally include a requirement for the restoration or enhancement, maintenance, and legal protection (e.g., conservation easements) of riparian areas next to open waters. In some cases, the restoration or maintenance/protection of riparian areas may be the only compensatory mitigation required. Restored riparian areas should consist of native species. The width of the required riparian area will address documented water quality or aquatic habitat loss concerns. Normally, the riparian area will be 25 to 50 feet wide on each side of the stream, but the district engineer may require slightly wider riparian areas to address documented water quality or habitat loss concerns. If it is not possible to restore or maintain/protect a riparian area on both sides of a stream, or if the waterbody is a lake or coastal waters, then restoring or maintaining/protecting a riparian area along a single bank or shoreline may be sufficient. Where both wetlands and open waters exist on the project site, the district engineer will determine the appropriate compensatory mitigation (e.g., riparian areas and/or wetlands compensation) based on what is best for the aquatic environment on a watershed basis. In cases where riparian areas are determined to be the most appropriate form of minimization or compensatory mitigation, the district engineer may waive or reduce the requirement to provide wetland compensatory mitigation for wetland losses.
  - (f) Compensatory mitigation projects provided to offset losses of aquatic resources must comply with the applicable provisions of 33 CFR part 332.



- (1) The prospective permittee is responsible for proposing an appropriate compensatory mitigation option if compensatory mitigation is necessary to ensure that the activity results in no more than minimal adverse environmental effects. For the NWP, the preferred mechanism for providing compensatory mitigation is mitigation bank credits or in-lieu fee program credits (see 33 CFR 332.3(b)(2) and (3)). However, if an appropriate number and type of mitigation bank or in-lieu credits are not available at the time the PCN is submitted to the district engineer, the district engineer may approve the use of permittee-responsible mitigation.
  - (2) The amount of compensatory mitigation required by the district engineer must be sufficient to ensure that the authorized activity results in no more than minimal individual and cumulative adverse environmental effects (see 33 CFR 330.1(e)(3)). (See also 33 CFR 332.3(f)).
  - (3) Since the likelihood of success is greater and the impacts to potentially valuable uplands are reduced, aquatic resource restoration should be the first compensatory mitigation option considered for permittee-responsible mitigation.
  - (4) If permittee-responsible mitigation is the proposed option, the prospective permittee is responsible for submitting a mitigation plan. A conceptual or detailed mitigation plan may be used by the district engineer to make the decision on the NWP verification request, but a final mitigation plan that addresses the applicable requirements of 33 CFR 332.4(c)(2) through (14) must be approved by the district engineer before the permittee begins work in waters of the United States, unless the district engineer determines that prior approval of the final mitigation plan is not practicable or not necessary to ensure timely completion of the required compensatory mitigation (see 33 CFR 332.3(k)(3)).
  - (5) If mitigation bank or in-lieu fee program credits are the proposed option, the mitigation plan only needs to address the baseline conditions at the impact site and the number of credits to be provided.
  - (6) Compensatory mitigation requirements (e.g., resource type and amount to be provided as compensatory mitigation, site protection, ecological performance standards, monitoring requirements) may be addressed through conditions added to the NWP authorization, instead of components of a compensatory mitigation plan (see 33 CFR 332.4(c)(1)(ii)).
  - (g) Compensatory mitigation will not be used to increase the acreage losses allowed by the acreage limits of the NWPs. For example, if an NWP has an acreage limit of 1/2-acre, it cannot be used to authorize any NWP activity resulting in the loss of greater than 1/2-acre of waters of the United States, even if compensatory mitigation is provided that replaces or restores some of the lost waters. However, compensatory mitigation can and should be used, as necessary, to ensure that an NWP activity already meeting the established acreage limits also satisfies the no more than minimal impact requirement for the NWPs.
  - (h) Permittees may propose the use of mitigation banks, in-lieu fee programs, or permittee-responsible mitigation. When developing a compensatory mitigation proposal, the permittee must consider appropriate and practicable options consistent with the framework at 33 CFR 332.3(b). For activities resulting in the loss of marine or estuarine resources, permittee-responsible mitigation may be environmentally preferable if there are no mitigation banks or in-lieu fee programs in the area that have marine or estuarine credits available for sale or transfer to the permittee. For permittee-responsible mitigation, the special conditions of the NWP verification must clearly indicate the party or parties responsible for the implementation and performance of the compensatory mitigation project, and, if required, its long-term management.
  - (i) Where certain functions and services of waters of the United States are permanently adversely affected by a regulated activity, such as discharges of dredged or fill material into waters of the United States that will convert a forested or scrub-shrub wetland to a herbaceous wetland in a permanently maintained utility line right-of-way, mitigation may be required to reduce the adverse environmental effects of the activity to the no more than minimal level.
24. Safety of Impoundment Structures. To ensure that all impoundment structures are safely designed, the district engineer may require non-Federal applicants to demonstrate that the structures comply with established state dam safety criteria or have been designed by qualified persons. The district engineer may also require documentation that the design has been independently reviewed by similarly qualified persons, and appropriate modifications made to ensure safety.
  25. Water Quality. Where States and authorized Tribes, or EPA where applicable, have not previously certified compliance of an NWP with CWA section 401, individual 401 Water Quality Certification must be obtained or waived (see 33 CFR 330.4(c)). The district engineer or State or Tribe may require additional water quality management measures to ensure that the authorized activity does not result in more than minimal degradation of water quality.
  26. Coastal Zone Management. In coastal states where an NWP has not previously received a state coastal zone management consistency concurrence, an individual state coastal zone management consistency concurrence must be obtained, or a presumption of concurrence must occur (see 33 CFR 330.4(d)). The district engineer or a State may require additional measures to ensure that the authorized activity is consistent with state coastal zone management requirements.
  27. Regional and Case-By-Case Conditions. The activity must comply with any regional conditions that may have been added by the Division Engineer (see 33 CFR 330.4(e)) and with any case specific conditions added by the Corps or by the state, Indian Tribe, or U.S. EPA in its section 401 Water Quality Certification, or by the state in its Coastal Zone Management Act consistency determination.
  28. Use of Multiple Nationwide Permits. The use of more than one NWP for a single and complete project is prohibited, except when the acreage loss of waters of the United States authorized by the NWPs does not exceed the acreage limit of the NWP with the highest specified acreage limit. For example, if a road crossing over tidal waters is constructed

- under NWP 14, with associated bank stabilization authorized by NWP 13, the maximum acreage loss of waters of the United States for the total project cannot exceed 1/3-acre.
29. Transfer of Nationwide Permit Verifications. If the permittee sells the property associated with a nationwide permit verification, the permittee may transfer the nationwide permit verification to the new owner by submitting a letter to the appropriate Corps district office to validate the transfer. A copy of the nationwide permit verification must be attached to the letter, and the letter must contain the following statement and signature: When the structures or work authorized by this nationwide permit are still in existence at the time the property is transferred, the terms and conditions of this nationwide permit, including any special conditions, will continue to be binding on the new owner(s) of the property. To validate the transfer of this nationwide permit and the associated liabilities associated with compliance with its terms and conditions, have the transferee sign and date below.

-----  
(Transferee)  
-----

(Date)

30. Compliance Certification. Each permittee who receives an NWP verification letter from the Corps must provide a signed certification documenting completion of the authorized activity and implementation of any required compensatory mitigation. The success of any required permittee-responsible mitigation, including the achievement of ecological performance standards, will be addressed separately by the district engineer. The Corps will provide the permittee the certification document with the NWP verification letter. The certification document will include:
- (a) A statement that the authorized activity was done in accordance with the NWP authorization, including any general, regional, or activity-specific conditions;
  - (b) A statement that the implementation of any required compensatory mitigation was completed in accordance with the permit conditions. If credits from a mitigation bank or in-lieu fee program are used to satisfy the compensatory mitigation requirements, the certification must include the documentation required by 33 CFR 332.3(l)(3) to confirm that the permittee secured the appropriate number and resource type of credits; and
  - (c) The signature of the permittee certifying the completion of the activity and mitigation. The completed certification document must be submitted to the district engineer within 30 days of completion of the authorized activity or the implementation of any required compensatory mitigation, whichever occurs later.
31. Activities Affecting Structures or Works Built by the United States. If an NWP activity also requires permission from the Corps pursuant to 33 U.S.C. 408 because it will alter or temporarily or permanently occupy or use a U.S. Army Corps of Engineers (USACE) federally authorized Civil Works project (a "USACE project"), the prospective permittee must submit a pre-construction notification. See paragraph (b)(10) of general condition 32. An activity that requires section 408 permission is not authorized by NWP until the appropriate Corps office issues the section 408 permission to alter, occupy, or use the USACE project, and the district engineer issues a written NWP verification.
32. Pre-Construction Notification. (a) Timing. Where required by the terms of the NWP, the prospective permittee must notify the district engineer by submitting a pre-construction notification (PCN) as early as possible. The district engineer must determine if the PCN is complete within 30 calendar days of the date of receipt and, if the PCN is determined to be incomplete, notify the prospective permittee within that 30 day period to request the additional information necessary to make the PCN complete. The request must specify the information needed to make the PCN complete. As a general rule, district engineers will request additional information necessary to make the PCN complete only once. However, if the prospective permittee does not provide all of the requested information, then the district engineer will notify the prospective permittee that the PCN is still incomplete and the PCN review process will not commence until all of the requested information has been received by the district engineer. The prospective permittee shall not begin the activity until either:
- (1) He or she is notified in writing by the district engineer that the activity may proceed under the NWP with any special conditions imposed by the district or division engineer; or
  - (2) 45 calendar days have passed from the district engineer's receipt of the complete PCN and the prospective permittee has not received written notice from the district or division engineer. However, if the permittee was required to notify the Corps pursuant to general condition 18 that listed species or critical habitat might be affected or are in the vicinity of the activity, or to notify the Corps pursuant to general condition 20 that the activity might have the potential to cause effects to historic properties, the permittee cannot begin the activity until receiving written notification from the Corps that there is "no effect" on listed species or "no potential to cause effects" on historic properties, or that any consultation required under Section 7 of the Endangered Species Act (see 33 CFR 330.4(f)) and/or section 106 of the National Historic Preservation Act (see 33 CFR 330.4(g)) has been completed. Also, work cannot begin under NWPs 21, 49, or 50 until the permittee has received written approval from the Corps. If the proposed activity requires a written waiver to exceed specified limits of an NWP, the permittee may not begin the activity until the district engineer issues the waiver. If the district or division engineer notifies the permittee in writing that an individual permit is required within 45 calendar days of receipt of a complete PCN, the permittee cannot begin the activity until an individual permit has been obtained. Subsequently, the permittee's right to proceed under the NWP may be modified, suspended, or revoked only in accordance with the procedure set forth in 33 CFR 330.5(d)(2).

- (b) Contents of Pre-Construction Notification: The PCN must be in writing and include the following information:
- (1) Name, address and telephone numbers of the prospective permittee;
  - (2) Location of the proposed activity;
  - (3) Identify the specific NWP or NWP(s) the prospective permittee wants to use to authorize the proposed activity;
  - (4) A description of the proposed activity; the activity's purpose; direct and indirect adverse environmental effects the activity would cause, including the anticipated amount of loss of wetlands, other special aquatic sites, and other waters expected to result from the NWP activity, in acres, linear feet, or other appropriate unit of measure; a description of any proposed mitigation measures intended to reduce the adverse environmental effects caused by the proposed activity; and any other NWP(s), regional general permit(s), or individual permit(s) used or intended to be used to authorize any part of the proposed project or any related activity, including other separate and distant crossings for linear projects that require Department of the Army authorization but do not require pre-construction notification. The description of the proposed activity and any proposed mitigation measures should be sufficiently detailed to allow the district engineer to determine that the adverse environmental effects of the activity will be no more than minimal and to determine the need for compensatory mitigation or other mitigation measures. For single and complete linear projects, the PCN must include the quantity of anticipated losses of wetlands, other special aquatic sites, and other waters for each single and complete crossing of those wetlands, other special aquatic sites, and other waters. Sketches should be provided when necessary to show that the activity complies with the terms of the NWP. (Sketches usually clarify the activity and when provided results in a quicker decision. Sketches should contain sufficient detail to provide an illustrative description of the proposed activity (e.g., a conceptual plan), but do not need to be detailed engineering plans);
  - (5) The PCN must include a delineation of wetlands, other special aquatic sites, and other waters, such as lakes and ponds, and perennial, intermittent, and ephemeral streams, on the project site. Wetland delineations must be prepared in accordance with the current method required by the Corps. The permittee may ask the Corps to delineate the special aquatic sites and other waters on the project site, but there may be a delay if the Corps does the delineation, especially if the project site is large or contains many wetlands, other special aquatic sites, and other waters. Furthermore, the 45 day period will not start until the delineation has been submitted to or completed by the Corps, as appropriate;
  - (6) If the proposed activity will result in the loss of greater than 1/10-acre of wetlands and a PCN is required, the prospective permittee must submit a statement describing how the mitigation requirement will be satisfied, or explaining why the adverse environmental effects are no more than minimal and why compensatory mitigation should not be required. As an alternative, the prospective permittee may submit a conceptual or detailed mitigation plan.
  - (7) For non-Federal permittees, if any listed species or designated critical habitat might be affected or is in the vicinity of the activity, or if the activity is located in designated critical habitat, the PCN must include the name(s) of those endangered or threatened species that might be affected by the proposed activity or utilize the designated critical habitat that might be affected by the proposed activity. For NWP activities that require pre-construction notification, Federal permittees must provide documentation demonstrating compliance with the Endangered Species Act;
  - (8) For non-Federal permittees, if the NWP activity might have the potential to cause effects to a historic property listed on, determined to be eligible for listing on, or potentially eligible for listing on, the National Register of Historic Places, the PCN must state which historic property might have the potential to be affected by the proposed activity or include a vicinity map indicating the location of the historic property. For NWP activities that require pre-construction notification, Federal permittees must provide documentation demonstrating compliance with section 106 of the National Historic Preservation Act;
  - (9) For an activity that will occur in a component of the National Wild and Scenic River System, or in a river officially designated by Congress as a "study river" for possible inclusion in the system while the river is in an official study status, the PCN must identify the Wild and Scenic River or the "study river" (see general condition 16); and
  - (10) For an activity that requires permission from the Corps pursuant to 33 U.S.C. 408 because it will alter or temporarily or permanently occupy or use a U.S. Army Corps of Engineers federally authorized civil works project, the pre-construction notification must include a statement confirming that the project proponent has submitted a written request for section 408 permission from the Corps office having jurisdiction over that USACE project.
- (c) Form of Pre-Construction Notification: The standard individual permit application form (Form ENG 4345) may be used, but the completed application form must clearly indicate that it is an NWP PCN and must include all of the applicable information required in paragraphs (b)(1) through (10) of this general condition. A letter containing the required information may also be used. Applicants may provide electronic files of PCNs and supporting materials if the district engineer has established tools and procedures for electronic submittals.
- (d) Agency Coordination: (1) The district engineer will consider any comments from Federal and state agencies concerning the proposed activity's compliance with the terms and conditions of the NWPs and the need for mitigation to reduce the activity's adverse environmental effects so that they are no more than minimal.

- (2) Agency coordination is required for: (i) All NWP activities that require pre-construction notification and result in the loss of greater than 1/2-acre of waters of the United States; (ii) NWP 21, 29, 39, 40, 42, 43, 44, 50, 51, and 52 activities that require pre-construction notification and will result in the loss of greater than 300 linear feet of stream bed; (iii) NWP 13 activities in excess of 500 linear feet, fills greater than one cubic yard per running foot, or involve discharges of dredged or fill material into special aquatic sites; and (iv) NWP 54 activities in excess of 500 linear feet, or that extend into the waterbody more than 30 feet from the mean low water line in tidal waters or the ordinary high water mark in the Great Lakes.
- (3) When agency coordination is required, the district engineer will immediately provide (e.g., via email, facsimile transmission, overnight mail, or other expeditious manner) a copy of the complete PCN to the appropriate Federal or state offices (FWS, state natural resource or water quality agency, EPA, and, if appropriate, the NMFS). With the exception of NWP 37, these agencies will have 10 calendar days from the date the material is transmitted to notify the district engineer via telephone, facsimile transmission, or email that they intend to provide substantive, site-specific comments. The comments must explain why the agency believes the adverse environmental effects will be more than minimal. If so contacted by an agency, the district engineer will fully consider agency comments received within the specified time frame concerning the proposed activity's compliance with the terms and conditions of the NWPs, including the need for mitigation to ensure the net adverse environmental effects of the proposed activity are no more than minimal. The district engineer will provide no response to the resource agency, except as provided below. The district engineer will indicate in the administrative record associated with each pre-construction notification that the resource agencies' concerns were considered. For NWP 37, the emergency watershed protection and rehabilitation activity may proceed immediately in cases where there is an unacceptable hazard to life or a significant loss of property or economic hardship will occur. The district engineer will consider any comments received to decide whether the NWP 37 authorization should be modified, suspended, or revoked in accordance with the procedures at 33 CFR 330.5.
- (4) In cases of where the prospective permittee is not a Federal agency, the district engineer will provide a response to NMFS within 30 calendar days of receipt of any Essential Fish Habitat conservation recommendations, as required by section 305(b)(4)(B) of the Magnuson-Stevens Fishery Conservation and Management Act.
- (5) Applicants are encouraged to provide the Corps with either electronic files or multiple copies of preconstruction notifications to expedite agency coordination.

#### **D. District Engineer's Decision**

1. In reviewing the PCN for the proposed activity, the district engineer will determine whether the activity authorized by the NWP will result in more than minimal individual or cumulative adverse environmental effects or may be contrary to the public interest. If a project proponent requests authorization by a specific NWP, the district engineer should issue the NWP verification for that activity if it meets the terms and conditions of that NWP, unless he or she determines, after considering mitigation, that the proposed activity will result in more than minimal individual and cumulative adverse effects on the aquatic environment and other aspects of the public interest and exercises discretionary authority to require an individual permit for the proposed activity. For a linear project, this determination will include an evaluation of the individual crossings of waters of the United States to determine whether they individually satisfy the terms and conditions of the NWP(s), as well as the cumulative effects caused by all of the crossings authorized by NWP. If an applicant requests a waiver of the 300 linear foot limit on impacts to streams or of an otherwise applicable limit, as provided for in NWPs 13, 21, 29, 36, 39, 40, 42, 43, 44, 50, 51, 52, or 54, the district engineer will only grant the waiver upon a written determination that the NWP activity will result in only minimal individual and cumulative adverse environmental effects. For those NWPs that have a waivable 300 linear foot limit for losses of intermittent and ephemeral stream bed and a 1/2-acre limit (i.e., NWPs 21, 29, 39, 40, 42, 43, 44, 50, 51, and 52), the loss of intermittent and ephemeral stream bed, plus any other losses of jurisdictional waters and wetlands, cannot exceed 1/2-acre.

2. When making minimal adverse environmental effects determinations the district engineer will consider the direct and indirect effects caused by the NWP activity. He or she will also consider the cumulative adverse environmental effects caused by activities authorized by NWP and whether those cumulative adverse environmental effects are no more than minimal. The district engineer will also consider site specific factors, such as the environmental setting in the vicinity of the NWP activity, the type of resource that will be affected by the NWP activity, the functions provided by the aquatic resources that will be affected by the NWP activity, the degree or magnitude to which the aquatic resources perform those functions, the extent that aquatic resource functions will be lost as a result of the NWP activity (e.g., partial or complete loss), the duration of the adverse effects (temporary or permanent), the importance of the aquatic resource functions to the region (e.g., watershed or ecoregion), and mitigation required by the district engineer. If an appropriate functional or condition assessment method is available and practicable to use, that assessment method may be used by the district engineer to assist in the minimal adverse environmental effects determination. The district engineer may add case-specific special conditions to the NWP authorization to address site-specific environmental concerns.

3. If the proposed activity requires a PCN and will result in a loss of greater than 1/10-acre of wetlands, the prospective permittee should submit a mitigation proposal with the PCN. Applicants may also propose compensatory mitigation for NWP activities with smaller impacts, or for impacts to other types of waters (e.g., streams). The district engineer will consider any

proposed compensatory mitigation or other mitigation measures the applicant has included in the proposal in determining whether the net adverse environmental effects of the proposed activity are no more than minimal. The compensatory mitigation proposal may be either conceptual or detailed. If the district engineer determines that the activity complies with the terms and conditions of the NWP and that the adverse environmental effects are no more than minimal, after considering mitigation, the district engineer will notify the permittee and include any activity-specific conditions in the NWP verification the district engineer deems necessary. Conditions for compensatory mitigation requirements must comply with the appropriate provisions at 33 CFR 332.3(k). The district engineer must approve the final mitigation plan before the permittee commences work in waters of the United States, unless the district engineer determines that prior approval of the final mitigation plan is not practicable or not necessary to ensure timely completion of the required compensatory mitigation. If the prospective permittee elects to submit a compensatory mitigation plan with the PCN, the district engineer will expeditiously review the proposed compensatory mitigation plan. The district engineer must review the proposed compensatory mitigation plan within 45 calendar days of receiving a complete PCN and determine whether the proposed mitigation would ensure the NWP activity results in no more than minimal adverse environmental effects. If the net adverse environmental effects of the NWP activity (after consideration of the mitigation proposal) are determined by the district engineer to be no more than minimal, the district engineer will provide a timely written response to the applicant. The response will state that the NWP activity can proceed under the terms and conditions of the NWP, including any activity-specific conditions added to the NWP authorization by the district engineer.

4. If the district engineer determines that the adverse environmental effects of the proposed activity are more than minimal, then the district engineer will notify the applicant either: (a) That the activity does not qualify for authorization under the NWP and instruct the applicant on the procedures to seek authorization under an individual permit; (b) that the activity is authorized under the NWP subject to the applicant's submission of a mitigation plan that would reduce the adverse environmental effects so that they are no more than minimal; or (c) that the activity is authorized under the NWP with specific modifications or conditions. Where the district engineer determines that mitigation is required to ensure no more than minimal adverse environmental effects, the activity will be authorized within the 45-day PCN period (unless additional time is required to comply with general conditions 18, 20, and/or 31, or to evaluate PCNs for activities authorized by NWPs 21, 49, and 50), with activity-specific conditions that state the mitigation requirements. The authorization will include the necessary conceptual or detailed mitigation plan or a requirement that the applicant submit a mitigation plan that would reduce the adverse environmental effects so that they are no more than minimal. When compensatory mitigation is required, no work in waters of the United States may occur until the district engineer has approved a specific mitigation plan or has determined that prior approval of a final mitigation plan is not practicable or not necessary to ensure timely completion of the required compensatory mitigation.

#### **E. Further Information**

1. District Engineers have authority to determine if an activity complies with the terms and conditions of an NWP.
2. NWPs do not obviate the need to obtain other federal, state, or local permits, approvals, or authorizations required by law.
3. NWPs do not grant any property rights or exclusive privileges.
4. NWPs do not authorize any injury to the property or rights of others.
5. NWPs do not authorize interference with any existing or proposed Federal project (see General condition 32).

#### **F. Definitions**

Best management practices (BMPs): Policies, practices, procedures, or structures implemented to mitigate the adverse environmental effects on surface water quality resulting from development. BMPs are categorized as structural or non-structural.

Compensatory mitigation: The restoration (re-establishment or rehabilitation), establishment (creation), enhancement, and/or in certain circumstances preservation of aquatic resources for the purposes of offsetting unavoidable adverse impacts which remain after all appropriate and practicable avoidance and minimization has been achieved.

Currently serviceable: Useable as is or with some maintenance, but not so degraded as to essentially require reconstruction.

Direct effects: Effects that are caused by the activity and occur at the same time and place.

Discharge: The term "discharge" means any discharge of dredged or fill material into waters of the United States.

Ecological reference: A model used to plan and design an aquatic habitat and riparian area restoration, enhancement, or establishment activity under NWP 27. An ecological reference may be based on the structure, functions, and dynamics of an aquatic habitat type or a riparian area type that currently exists in the region where the proposed NWP 27 activity is located. Alternatively, an ecological reference may be based on a conceptual model for the aquatic habitat type or riparian area type to be restored, enhanced, or established as a result of the proposed NWP 27 activity. An ecological reference takes into account the range of variation of the aquatic habitat type or riparian area type in the region.

Enhancement: The manipulation of the physical, chemical, or biological characteristics of an aquatic resource to heighten, intensify, or improve a specific aquatic resource function(s).

Enhancement results in the gain of selected aquatic resource function(s), but may also lead to a decline in other aquatic resource function(s). Enhancement does not result in a gain in aquatic resource area.

Ephemeral stream: An ephemeral stream has flowing water only during, and for a short duration after, precipitation events in a typical year. Ephemeral stream beds are located above the water table year-round. Groundwater is not a source of water for the stream. Runoff from rainfall is the primary source of water for stream flow.

Establishment (creation): The manipulation of the physical, chemical, or biological characteristics present to develop an aquatic resource that did not previously exist at an upland site. Establishment results in a gain in aquatic resource area.

High Tide Line: The line of intersection of the land with the water's surface at the maximum height reached by a rising tide. The high tide line may be determined, in the absence of actual data, by a line of oil or scum along shore objects, a more or less continuous deposit of fine shell or debris on the foreshore or berm, other physical markings or characteristics, vegetation lines, tidal gages, or other suitable means that delineate the general height reached by a rising tide. The line encompasses spring high tides and other high tides that occur with periodic frequency but does not include storm surges in which there is a departure from the normal or predicted reach of the tide due to the piling up of water against a coast by strong winds such as those accompanying a hurricane or other intense storm.

Historic Property: Any prehistoric or historic district, site (including archaeological site), building, structure, or other object included in, or eligible for inclusion in, the National Register of Historic Places maintained by the Secretary of the Interior. This term includes artifacts, records, and remains that are related to and located within such properties. The term includes properties of traditional religious and cultural importance to an Indian tribe or Native Hawaiian organization and that meet the National Register criteria (36 CFR part 60).

Independent utility: A test to determine what constitutes a single and complete non-linear project in the Corps Regulatory Program. A project is considered to have independent utility if it would be constructed absent the construction of other projects in the project area. Portions of a multi-phase project that depend upon other phases of the project do not have independent utility. Phases of a project that would be constructed even if the other phases were not built can be considered as separate single and complete projects with independent utility.

Indirect effects: Effects that are caused by the activity and are later in time or farther removed in distance, but are still reasonably foreseeable.

Intermittent stream: An intermittent stream has flowing water during certain times of the year, when groundwater provides water for stream flow. During dry periods, intermittent streams may not have flowing water. Runoff from rainfall is a supplemental source of water for stream flow.

Loss of waters of the United States: Waters of the United States that are permanently adversely affected by filling, flooding, excavation, or drainage because of the regulated activity. Permanent adverse effects include permanent discharges of dredged or fill material that change an aquatic area to dry land, increase the bottom elevation of a waterbody, or change the use of a waterbody. The acreage of loss of waters of the United States is a threshold measurement of the impact to jurisdictional waters for determining whether a project may qualify for an NWP; it is not a net threshold that is calculated after considering compensatory mitigation that may be used to offset losses of aquatic functions and services. The loss of stream bed includes the acres or linear feet of stream bed that are filled or excavated as a result of the regulated activity. Waters of the United States temporarily filled, flooded, excavated, or drained, but restored to pre-construction contours and elevations after construction, are not included in the measurement of loss of waters of the United States. Impacts resulting from activities that do not require Department of the Army authorization, such as activities eligible for exemptions under section 404(f) of the Clean Water Act, are not considered when calculating the loss of waters of the United States.

Navigable waters: Waters subject to Section 10 of the Rivers and Harbors Act of 1899. These waters are defined at 33 CFR part 329.

Non-tidal wetland: A non-tidal wetland is a wetland that is not subject to the ebb and flow of tidal waters. Non-tidal wetlands contiguous to tidal waters are located landward of the high tide line (i.e., spring high tide line).

Open water: For purposes of the NWPs, an open water is any area that in a year with normal patterns of precipitation has water flowing or standing above ground to the extent that an ordinary high water mark can be determined. Aquatic vegetation within the area of flowing or standing water is either non-emergent, sparse, or absent. Vegetated shallows are considered to be open waters. Examples of "open waters" include rivers, streams, lakes, and ponds.

Ordinary High Water Mark: An ordinary high water mark is a line on the shore established by the fluctuations of water and indicated by physical characteristics, or by other appropriate means that consider the characteristics of the surrounding areas.

Perennial stream: A perennial stream has flowing water year-round during a typical year. The water table is located above the stream bed for most of the year. Groundwater is the primary source of water for stream flow. Runoff from rainfall is a supplemental source of water for stream flow.

Practicable: Available and capable of being done after taking into consideration cost, existing technology, and logistics in light of overall project purposes.

Pre-construction notification: A request submitted by the project proponent to the Corps for confirmation that a particular activity is authorized by nationwide permit. The request maybe a permit application, letter, or similar document that includes information about the proposed work and its anticipated environmental effects. Pre-construction notification may be required by the terms and conditions of a nationwide permit, or by regional conditions. A pre-construction notification may be voluntarily submitted in cases where pre-construction notification is not required and the project proponent wants confirmation that the activity is authorized by nationwide permit.

Preservation: The removal of a threat to, or preventing the decline of, aquatic resources by an action in or near those aquatic resources. This term includes activities commonly associated with the protection and maintenance of aquatic resources through the implementation of appropriate legal and physical mechanisms. Preservation does not result in a gain of aquatic resource area or functions.

Protected tribal resources: Those natural resources and properties of traditional or customary religious or cultural importance, either on or off Indian lands, retained by, or reserved by or for, Indian tribes through treaties, statutes, judicial decisions, or executive orders, including tribal trust resources.

Re-establishment: The manipulation of the physical, chemical, or biological characteristics of a site with the goal of returning natural/historic functions to a former aquatic resource. Re-establishment results in rebuilding a former aquatic resource and results in a gain in aquatic resource area and functions.

Rehabilitation: The manipulation of the physical, chemical, or biological characteristics of a site with the goal of repairing natural/historic functions to a degraded aquatic resource. Rehabilitation results in a gain in aquatic resource function, but does not result in a gain in aquatic resource area.

Restoration: The manipulation of the physical, chemical, or biological characteristics of a site with the goal of returning natural/historic functions to a former or degraded aquatic resource. For the purpose of tracking net gains in aquatic resource area, restoration is divided into two categories: Re-establishment and rehabilitation.

Riffle and pool complex: Riffle and pool complexes are special aquatic sites under the 404(b)(1) Guidelines. Riffle and pool complexes sometimes characterize steep gradient sections of streams. Such stream sections are recognizable by their hydraulic characteristics. The rapid movement of water over a coarse substrate in riffles results in a rough flow, a turbulent surface, and high dissolved oxygen levels in the water. Pools are deeper areas associated with riffles. A slower stream velocity, a streaming flow, a smooth surface, and a finer substrate characterize pools.

Riparian areas: Riparian areas are lands next to streams, lakes, and estuarine-marine shorelines. Riparian areas are transitional between terrestrial and aquatic ecosystems, through which surface and subsurface hydrology connects riverine, lacustrine, estuarine, and marine waters with their adjacent wetlands, non-wetland waters, or uplands. Riparian areas provide a variety of ecological functions and services and help improve or maintain local water quality. (See general condition 23.)

Shellfish seeding: The placement of shellfish seed and/or suitable substrate to increase shellfish production. Shellfish seed consists of immature individual shellfish or individual shellfish attached to shells or shell fragments (i.e., spat on shell). Suitable substrate may consist of shellfish shells, shell fragments, or other appropriate materials placed into waters for shellfish habitat.

Single and complete linear project: A linear project is a project constructed for the purpose of getting people, goods, or services from a point of origin to a terminal point, which often involves multiple crossings of one or more waterbodies at separate and distant locations. The term "single and complete project" is defined as that portion of the total linear project proposed or accomplished by one owner/developer or partnership or other association of owners/developers that includes all crossings of a single water of the United States (i.e., a single waterbody) at a specific location. For linear projects crossing a single or multiple waterbodies several times at separate and distant locations, each crossing is considered a single and complete project for purposes of NWP authorization. However, individual channels in a braided stream or river, or individual arms of a large, irregularly shaped wetland or lake, etc., are not separate waterbodies, and crossings of such features cannot be considered separately.

Single and complete non-linear project: For non-linear projects, the term "single and complete project" is defined at 33 CFR 330.2(i) as the total project proposed or accomplished by one owner/developer or partnership or other association of owners/developers. A single and complete non-linear project must have independent utility (see definition of "independent utility"). Single and complete non-linear projects may not be "piecemealed" to avoid the limits in an NWP authorization.

Stormwater management: Stormwater management is the mechanism for controlling stormwater runoff for the purposes of reducing downstream erosion, water quality degradation, and flooding and mitigating the adverse effects of changes in land use on the aquatic environment.

Stormwater management facilities: Stormwater management facilities are those facilities, including but not limited to, stormwater retention and detention ponds and best management practices, which retain water for a period of time to control runoff and/or improve the quality

(i.e., by reducing the concentration of nutrients, sediments, hazardous substances and other pollutants) of stormwater runoff.

Stream bed: The substrate of the stream channel between the ordinary high water marks. The substrate may be bedrock or inorganic particles that range in size from clay to boulders. Wetlands contiguous to the stream bed, but outside of the ordinary high water marks, are not considered part of the stream bed.

Stream channelization: The manipulation of a stream's course, condition, capacity, or location that causes more than minimal interruption of normal stream processes. A channelized stream remains a water of the United States.

Structure: An object that is arranged in a definite pattern of organization. Examples of structures include, without limitation, any pier, boat dock, boat ramp, wharf, dolphin, weir, boom, breakwater, bulkhead, revetment, riprap, jetty, artificial island, artificial reef, permanent mooring structure, power transmission line, permanently moored floating vessel, piling, aid to navigation, or any other manmade obstacle or obstruction.

Tidal wetland: A tidal wetland is a jurisdictional wetland that is inundated by tidal waters. Tidal waters rise and fall in a predictable and measurable rhythm or cycle due to the gravitational pulls of the moon and sun. Tidal waters end where the rise and fall of the water surface can no longer be practically measured in a predictable rhythm due to masking by other waters, wind, or other effects. Tidal wetlands are located channelward of the high tide line.

Tribal lands: Any lands title to which is either: (1) Held in trust by the United States for the benefit of any Indian tribe or individual; or (2) held by any Indian tribe or individual subject to restrictions by the United States against alienation.

Tribal rights: Those rights legally accruing to a tribe or tribes by virtue of inherent sovereign authority, unextinguished aboriginal title, treaty, statute, judicial decisions, executive order or agreement, and that give rise to legally enforceable remedies.

Vegetated shallows: Vegetated shallows are special aquatic sites under the 404(b)(1) Guidelines. They are areas that are permanently inundated and under normal circumstances have rooted aquatic vegetation, such as seagrasses in marine and estuarine systems and a variety of vascular rooted plants in freshwater systems.

Waterbody: For purposes of the NWPs, a waterbody is a jurisdictional water of the United States. If a wetland is adjacent to a waterbody determined to be a water of the United States, that waterbody and any adjacent wetlands are considered together as a single aquatic unit (see 33 CFR 328.4(c)(2)). Examples of "waterbodies" include streams, rivers, lakes, ponds, and wetlands.

PCN - Pre-Construction Notification



**IOWA DEPARTMENT OF NATURAL RESOURCES  
SECTION 401 WATER QUALITY CERTIFICATION**

**Certification issued to:**

Anthony Nielsen  
2920 Manhattan Boulevard  
Wahpeton, IA 51360

**Project certified:** U.S. Army Corps of Engineers, No. CEMVR-OD-P-2021-1376  
State 401 Water Quality Certification, No. 21-W-059-09-05-S

**Project Description:** Place 2 short boulder walls and native field stone along 60' of West Okoboji Lake.

**Project Location:** 2920 Manhattan Boulevard, Wahpeton, S13, T99N, R37W, in Dickinson County.  
Latitude: 43.3948, Longitude: -95.1683.

The Iowa Department of Natural Resources (DNR) has issued this State 401 Water Quality Certification (Certification) pursuant to Section 401 {40 C.F.R. §121}. The U.S. Army Corps of Engineers requires state Certification before a Section 404 permit can be issued.

Subject to the attached conditions, incorporated by reference herein, the DNR has determined that a discharge from the proposed project will comply with water quality requirements of the state of Iowa {567 IAC 61}.

Prepared By: \_\_\_\_\_ Date Executed: \_\_\_\_\_, 2021  
Christine Schwake, [Christine.schwake@dnr.iowa.gov](mailto:Christine.schwake@dnr.iowa.gov); Iowa DNR, 502 East 9<sup>TH</sup> Street, Des Moines, IA 50319-0034  
(515) 725-8399

## CONDITIONS

- (1) During construction and upon completion of the project, actions must be taken to prevent pollution affecting public health, fish, shellfish, wildlife, and recreation due to turbidity, pH, nutrients, suspended solids, floating debris, visible oil and grease, or other pollutants entering a water of the state. This condition will ensure permittees comply with Iowa's narrative water quality standards found at 567 IAC 61.3(2);
- (2) Equipment used in waters of the state shall be cleaned of all hazardous materials, pesticides, fuels, lubricants, oils, hydraulic fluids, or other construction-related, potentially hazardous substances before arriving on site. Wash water shall not be discharged into a water of the state. This condition will ensure permittees comply with Iowa's narrative water quality standards found at 567 IAC 61.3(2);
- (3) All cleared vegetative material shall be properly managed in such a manner that it cannot enter a water of the state and cause a violation of water quality standards. This condition will ensure permittees comply with Iowa's narrative water quality standards found at 567 IAC 61.3(2);
- (4) All construction debris shall be properly managed in such a manner that it cannot enter a water of the state. This condition will ensure permittees comply with Iowa's narrative water quality standards found at 567 IAC 61.3(2);
- (5) Erosion shall be managed so that sediment is not discharged to a water of the state in a manner that causes a violation of water quality standards. This condition will ensure permittees comply with Iowa's narrative water quality standards found at 567 IAC 61.3(2); and
- (6) Riprap, treated lumber products, and temporary crossings shall consist of clean material free of coatings of potentially hazardous substances. No asphalt or petroleum-based material shall be used as or included in material placed in any water of the state or within the high-water table. This condition will ensure permittees comply with Iowa's narrative water quality standards found at 567 IAC 61.3(2).